

aksa POWER
GENERATION



10kVA-3000kVA

DIESEL GENERATING SETS INSTALLATION RECOMMENDATIONS AND OPERATION MANUAL

www.aksa.com.tr



**DIESEL GENERATING SETS
INSTALLATION RECOMMENDATIONS
AND
OPERATION MANUAL**

DIRECTORY

1. INTRODUCTION	01	8. LUBRICATING OIL	20
2. GENERAL SAFETY PRECAUTIONS INSTRUCTIONS	02	8.1. Oil performance properties	20
2.1. General	02	8.2. Lubrication recommendations for engine	20
2.2. Installation, handling, and towing	02	8.3. Lubricating oil replace	20
2.3. Fire and explosion	03	9. ELECTRIC STARTING SYSTEMS	20
2.4. Mechanical	03	9.1. Battery systems	20
2.5. Chemical	03	9.2. Maintenance batteries	20
2.6. Noise	04	9.3. Battery maintenance	21
2.7. Electrical	04	9.4. Maintenance free batteries	21
2.8. Exhaust gas protection	04	9.5. Starting aids	21
2.9. First aid for electric shock	05	10. ELECTRICAL CONNECTION	21
2.10. Recovery position	05	10.1. Cabling	21
3. GENERAL DESCRIPTION	06	10.2. Protection	22
3.1. Generating set description and identification	06	10.3. Loading	22
3.2. Diesel engine	07	10.4. Power factor	22
3.3. Engine electrical system	07	10.5. Grounding/Earthing requirements	22
3.4. Cooling system	07	10.6. Insulation test	22
3.5. Synchronous alternator	07	11. ACOUSTIC SILENCING	23
3.6. Coupling	08	11.1. Exhaust silencers	23
3.7. Fuel tank and base frame	08	11.2. Canopies	23
3.8. Vibration isolation	08	11.3. Other sound attenuation	23
3.9. Silencer and exhaust system	08	12. TOWING (Mobile Generating Sets)	23
3.10. Control system	08	12.1. Preparing to Tow	23
4. INSTALLATION, HANDLING AND STORAGE	09	12.2. Towing	23
4.1. General	09	12.3. Parking	23
4.2. Canopies	09	13. STORAGE	24
4.3. Moving the generating set	09	13.1. Engine storage	24
4.4. Location	09	13.2. Alternator storage	24
4.5. Base and foundation	10	13.3. Battery storage	24
4.6. Room design guidance notes	11	13.4. Standby gen-set	24
4.7. Bellows	13	14. GENERAL PRECAUTIONS AND CONTROLS WHICH MUST BE DONE BEFORE STARTING UP THE GENERATING SET,	24
5. FUEL SYSTEM	14	15. GENERATING SET CONTROL SYSTEMS	25
5.1. General	14	15.1. DSE6120, control system with automatic mains failure	25
5.2. Diesel fuel recommendations	14	15.2. DSE7320, control system with automatic mains failure	26
5.3. Base fuel tank	15	15.3. Operation mode	28
5.4. Bulk storage tanks	15	15.4. Other Push buttons and Starts/Measurement units	29
5.5. Without intermediate fuel tank (Figure.5.1.)	15	16. GENERAL PRECAUTIONS AND CONTROLS WHICH MUST BE DONE AFTER STARTING UP THE GENERATING SET	31
5.6. With intermediate fuel tank (Figure.5.2.)	15	17. THE PLACEMENT AND INTALLATION OF AUTOMATIC TRANSFER SWITCH (ATS)	32
5.7. Daily service fuel tank	16	18. ENGINE TROUBLESHOOTING	32
5.8. Determining pipe sizes	16	19. MAINTENANCE CHART	35
5.9. Fuel return lines	16	20. PRODUCT WARRANTY REGULATION	36
6. COOLANT TREATMENT	18	21. ELECTRICAL WIRING DIAGRAMS	37
6.1. General	18	22. TECHNICAL INFORMATION	38
6.2. Engine coolant	18		
6.3. Engine warming	18		
7. EXHAUST SYSTEM	19		
7.1. Sizing	19		
7.2. Routing	19		

1.INTRODUCTION

Save these instructions these instructions are important.

This operations and maintenance manual has been prepared to assist the operator with the proper operation and maintenance of the generating set. Observing the suggestions and rules in this manual will ensure that the generating set operates at maximum performance and efficiency throughout the life of the unit.

Required maintenance should be performed more frequent in dirty and dusty environments in order to keep the generating set in good working condition.

Each generating set indicates the model and serial numbers on the base frame. Also, each set has a data plate (See Below) indicating the manufacture date, voltage, and current, power in kVA, frequency, power factor, and weight of the generating set. This information will be necessary for spare part orders, warranty validity, and service calls.

AKSA		AKSA GENERATOR BANKA A.Ş.	
Müdürlüğüne Marmara Bulvarı Çarşı No:18 Kat:10 Beşiktaş / İstanbul / Türkiye		7.000 Çarşı Merkezi: 084 4 8500 / Çarşı Merkez: 084 404 4 800	
E-Posta: aksa@aksa.com.tr / www.aksa.com.tr			
MODEL	PRODUCT DATE	SERIAL NO	
PRIME KVA		STANDBY KVA	
PRIME A		STANDBY A	
ALTERNATOR MODEL		ALTERNATOR SERIAL NO	
DIMENSIONS L W H		FUEL TANK CAPACITY	
VOLTS		GROUP WEIGHT	ISO 8001 TS ISO 8528-4
Hz	Cosφ		ISO 14001 TS ISO 8528-5
PHASE	R.P.M		ISO 45001 TS EN ISO 1528-13 GENERATING SET
ETK-026-19			

Figure 1.1.

The generating set is designed to be safe when used properly. However, responsibility for safety rests with the personnel who install, use, and maintain the set. If the following safety precautions are followed, then the possibility of an accident is minimized. Before performing any procedure or operating technique, it is up to the user to ensure that it is safe. The generating set should only be operated by personnel who are authorized and trained.

Only people that have been properly trained should be allowed to operate, adjust, perform maintenance, or make repairs on Aksa Power Generation

equipment. It is the responsibility of the purchaser to appoint operators with the appropriate training and skill for each job category.

Skill level 1: Operator

An operator that is trained in all aspects of operating the unit with the push buttons and is also trained to know the safety aspects.

Skill level 2: Mechanical technician

A mechanical technician is trained to operate the unit with the same proficiency as the operator. The mechanical technician is also trained to perform maintenance and repair as described in the operation manual. A mechanical technician is allowed to change the settings of the controls and safety system. A mechanical technician does not work on live electrical components.

Skill level 3: Electrical technician

An electrical technician has the same qualifications as both the operator and the mechanical technician. The electrical technician may also carry out electrical repairs within the various enclosures of the unit. This includes work on live electrical components.

Skill level 4: Specialist from the manufacturer

This is a skilled specialist sent by the manufacturer or its agent to perform complex repairs or modifications to the equipment. It is recommended that not more than two people operate the unit; more operators could lead to unsafe operating conditions. Take necessary steps to keep all unauthorized personnel away from the unit to eliminate all possible source of danger at the unit.

The manufacturer does not accept any liability for damages caused by the use of non-original parts, Modifications, additions, or conversions made without the manufacturer's approval in writing.

2. GENERAL SAFETY PRECAUTIONS INSTRUCTIONS

2.1. General

1. The owner is responsible for maintaining the unit in a safe operating condition. Unit parts and accessories must be replaced if missing or unsuitable for safe operation.
2. Only operate this unit for its intended purpose and within its rated limits (pressure, temperature, speeds, etc.).
3. Gen-set and equipment shall be kept clean, i.e. as free as possible from oil, dust or other deposits.
4. To prevent an increase in operating temperature, inspect and clean heat transfer surfaces (cooler fins, intercoolers, water jackets, etc.) regularly.
5. Handle all substances with care. Keep spill containment supplies nearby in case of spills in order to prevent environmental hazards. Fuel and oil are flammable and should be kept away from any sources of ignition; the proper fire extinguisher should be kept nearby in case of fire.

WARNING

- ! Read and understand all safety precautions and warnings before operating or performing maintenance on the generating set.
- ! Failure to follow the instructions, procedures, and safety precautions in this manual may increase the possibility of accidents and injuries.
- ! Do not attempt to operate the generating set if any unsafe condition is known.
- ! If the generating set is unsafe, put danger notices and disconnect the battery negative (-) lead so that it cannot be started until the condition is corrected.
- ! Disconnect the battery negative (-) lead prior to attempting any repairs or cleaning inside the enclosure.
- ! Install and operate this generating set only in full compliance with relevant National, Local or Federal Codes, Standards or other requirements.

2.2. Installation, handling, and towing

Chapter 4 and 12 of this manual cover procedure for installation, handling and towing of generating sets. These chapters should be read before installing, moving and/or lifting the generating set or towing a mobile set. The following safety precautions should be noted:

WARNING

- ! Make electrical connections in compliance with relevant Electrical Codes, Standards or other requirements. This includes requirements for grounding and ground/earth faults.
- ! For stationary generating sets with remote fuel storage systems, make sure such systems are installed in compliance with relevant Codes, Standards or other requirements.
- ! Engine exhaust emissions are hazardous to personnel. The engine exhaust for all indoor generating sets must be piped outdoors via leak-free piping in compliance with relevant Codes, Standards and other requirements. Ensure that hot exhaust silencers and piping are clear of combustible material and are guarded for personnel protection per safety requirements. Ensure that fumes from the exhaust outlet will not be a hazard.
- ! Never lift the generating set by attaching to the engine or alternator lifting lugs, instead use the lifting points on the base frame or canopy.
- ! Ensure that the lifting rigging and supporting structure is in good condition and has a capacity suitable for the load.
- ! Keep all personnel away from the generating set when it is suspended.



2.3. Fire and explosion

Fuel and fumes associated with generating sets can be flammable and potentially explosive. Proper care in handling these materials can dramatically limit the risk of fire or explosion. However, safety dictates that fully charged BC and ABC fire extinguishers are kept on hand.

Personnel must know the specific uses for each one and how to operate them.

WARNING

! Ensure that the generating set room is properly ventilated.

! Keep the room, the floor and the generating set clean. When spills of fuel, oil, battery electrolyte or coolant occur, they should be cleaned up immediately.

! Never store flammable liquids near the engine.

! Do not smoke or allow sparks, flames, or other sources of ignition around fuel or batteries.



! Fuel vapors are explosive. Hydrogen gas generated by charging batteries is also explosive.

! Never store flammable liquids near the engine.

! Turn off or disconnect the power to the battery charger before making or breaking connections with the battery.

! To avoid arcing keep grounded conductive objects (such as tools) away from exposed live electrical parts (such as terminals). Sparks and arcing might ignite fuel or vapors.

! Avoid refilling the fuel tank while the engine is running.

! Do not attempt to operate the generating set with any known leaks in the fuel system.



2.4. Mechanical

The generating set is designed with guards for protection from moving parts. Care must still be taken to protect personnel and equipment from other mechanical hazards when working around the generating set.

WARNING

! Do not attempt to operate the generating set with the safety guards removed. While the generating set is running do not attempt to reach under or around the guards to do maintenance or for any other reason.

! Keep hands, arms, long hair, loose clothing and jewelers away from pulleys, belts and other moving parts.



Attention: Some moving parts cannot be seen clearly when the set is running.

! Keep access doors on enclosures closed and locked when not required to be open if equipped.



! Avoid contact with hot oil, hot coolant, hot exhaust gases, hot surfaces, sharp edges, and sharp corners.

! Wear protective clothing including gloves and hat when working around the generating set.

! Do not remove the radiator filler cap until the coolant has cooled. After cooling has taken place, loosen the cap slowly to relieve any excess pressure before removing the cap completely.



2.5. Chemical

Fuels, oils, coolants, lubricants, and the battery electrolyte used in this generating set are typical of the industry. However, they can be hazardous to personnel if not treated properly.

WARNING

! Do not swallow or allow skin contact with fuel, oil, coolant, lubricants, or the battery electrolyte. If swallowed, seek medical treatment immediately. Do not induce vomiting if fuel is swallowed. For skin contact, wash with soap and water.

! Do not wear clothing that has been contaminated by fuel or lube oil.

! Wear an acid resistant apron and face shield or goggles when servicing the battery.

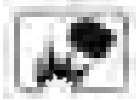

! If any electrolyte gets on skin or clothing, flush immediately with large quantities of water.

2.6. Noise

Generating sets that are not equipped with sound attenuating enclosures can produce noise levels in excess of 105 dB (A). Prolonged exposure to noise levels above 85 dB (A) is hazardous to hearing.

**WARNING**

Ear protection must be worn at all times when operating or working around an operating generating set.

2.7. Electrical

Safe and efficient operation of electrical equipment can be achieved only if the equipment is correctly installed, operated, and maintained.

WARNING

! The generating set must be connected to the load only by trained and qualified electricians who are authorized to do so. Connections must be made in compliance with relevant Electrical Codes, Standards and other regulations.

! Ensure that the generating set is effectively grounded in accordance to all relevant regulations

prior to operation.

! The generating set should be shut down with the battery negative (-) terminal disconnected prior to attempting to connect or disconnect load connections.

! Do not attempt to connect or disconnect load connections while standing in water or on wet or soggy ground.



! Do not touch electrically energized parts of the generating set and/or interconnecting cables or conductors with any part of the body or with any non-insulated conductive object.

! Replace the generating set terminal box cover as soon as connection or disconnection of the load cables is complete. Do not operate the generating set without the cover securely in place.

! Connect the generating set only to loads and/ or electrical systems that are compatible with its electrical characteristics and that are within its rated capacity.



! Keep all electrical equipment clean and dry. Replace any wiring where the insulation is cracked, cut, abraded or damaged in any other way. Replace terminals that are worn, discolored or corroded. Keep terminals clean and tight.

! Insulate all connections and disconnected wires.

! Use only Class BC or Class ABC extinguishers on electrical fires.

**2.8. Exhaust gas protection**

The gas of engine education contains the composition that is harmful to human body, make person acuteness cough, giddy, disgusting wait, and cause cancer even!

WARNING

! Please equip protective mask and keep away from engine exhaust to avoid inhaling engine exhaust .

2.9. First aid for electric shock

WARNING

! Do not touch the victim's skin with bare hands until the source of electricity has been turned off.

! If possible, switch the power off. Otherwise, pull the plug or cable away from the victim by its insulation or by using some other insulated device.

! If this is not possible, stand on any dry insulating material such as dry wood and pull the victim clear of the conductor.

! If the victim is breathing, turn the victim clear of the conductor, preferably using insulated material such as dry wood.

! If victim is breathing, turn the victim into the recovery position described below. If victim is unconscious, perform resuscitation as required:

Open the airway

Tilt the victim's head back and lift the chin upwards.

Remove objects from the mouth or throat (including false teeth, tobacco or chewing gum).

Breathing

Check that the victim is breathing by looking, listening and feeling for the breath.

Circulation

Check for pulse in the victim's neck.

If victim is not breathing, but pulse is present:

- Pinch the victim's nose firmly.
- Take a deep breath and seal your lips around the victim's lips.
- Blow slowly into the mouth watching for the chest to rise.
- Let the chest fall completely. Give breaths at a rate of 10 per minute.



- If the victim must be left to get help, give 10 breaths first and then return quickly and continue.
- Check for pulse after every 10 breaths. When breathing restarts, place the victim into the recovery position described later in this section.

If victim is not breathing and no pulse can be found:

- Call or telephone for medical help.
- Give two breaths and start chest compression as follows:



- Place heel of hand/2 fingers. Place above ribcage/breastbone junction.



- Place other hand on top and interlock fingers.
- keeping arms straight, press down 4-5 cm at a rate of 15 times per minute.



- Repeat cycle (2 breaths and 15 compressions) until medical help takes over.
- If condition improves, confirm pulse and continue with breaths.
- Check for pulse after every 10 breaths.
- when breathing restarts, place the victim into the recovery position described below.

2.10. Recovery position

- Turn the victim onto the side.
- Keep the head tilted with the jaw forward to maintain the open airway.
- Make sure the victim cannot roll forwards or backwards.
- Check for breathing and pulse regularly. If either stops, proceed as above.



WARNING

! Do not give liquids until victim is conscious.

3. GENERAL DESCRIPTION

3.1. Generating set description and identification

Diesel-electric generating sets are independent units for the production of electric power comprised of a constant voltage synchronous generator driven by an internal - combustion, diesel-cycle engine.

The sets are used for two main purposes:

A-Continuous duty sets,

These are used to produce electric power for countless requirements (lighting, heating, etc) in areas where other sources of power are unavailable.

B- Emergency duty sets,

These are used in such instances where public utility failures are liable to cause damage to lives, to materials, to finances, (i.e. hospitals, industrial plants with non-stop operating cycles, etc)or to meet peak energy demands.

According to their application, the sets are further divided into:

- set for use on land
- set for use at sea

The sets for use on land can be either:

- Stationary sets (fixed installation), or
- Mobile sets (mobile installation)

These two types of sets are available in a vast range of versions for every operating requirement with the main ones being:

- hand control generating sets
- Stand-by generating sets

The standard stationary generating set comprises:

- Diesel engine
- Synchronous generator
- coupling
- Metal sub-base with vibration isolators

- Starter batteries
- Fuel tank within the bed-plate
- Instrument panel
- exhaust gas silencer.

The normal temperature range for the operation of this gen-set is -15 C—50 C. If the temperature drops below -5 C, a heater may be required to aid start.

This Aksa Generating Set has been designed as a complete package to provide superior performance and reliability. Figure

3. 1.1. Shows a typical generating set with major components labeled. However, each set will be slightly different due to the size and configuration of the major components. This section briefly describes the parts of the generating set. Further information is provided in later sections of this manual.

Each generating set is provided with a Rating Label (Item 1) generally fixed to the base frame. This label contains the information needed to identify the generating set and its operating characteristics. This information includes the model number, serial number, output characteristics such as voltage and frequency, output rating in kVA and kW, product date and weight.

The model and serial numbers uniquely identify the generating set and are needed when ordering spare parts or obtaining service or warranty work for the set. AC series generating sets are Alternating Current generators, built for continuous operating at sites where no electricity is available (some models are excepted) or as stand-by in case of interruption of the main utility power.

3.1.2. Generating set main parts

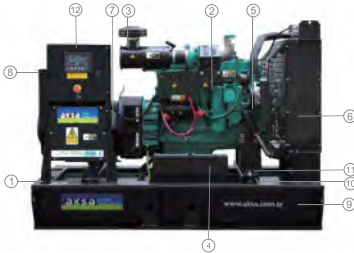

Figure 3.1. Typical generating set configuration

No	Description
1	Aksa generating set rating label
2	Diesel engine
3	Air filter
4	Battery
5	Battery charging alternator
6	Radiator
7	Alternator
8	Terminal box
9	Base frame
10	Fuel tank (inside the base frame)
11	Vibration isolators
12	Control Panel

Table 3.1.

3.2. Diesel engine

The diesel engine powering the generating set (Item 2) has been chosen for its reliability and the fact that it has been specifically designed for powering generating sets.

It has a heavy duty, industrial engine with a four-stroke compression ignition system.

It has been fitted with all accessories necessary

to provide a reliable power supply. These accessories include, among others, a cartridge type dry-air filter (item 3) and either a mechanical or an electronic engine speed governor. The engine cylinder block is one piece cast iron, vertical cylinders with inline overhead valves, and camshaft in block or V-type, according to the type.

The thermally loaded flame plate is efficiently water cooled. The crankshaft is forged in one piece in a high tensile steel.

Lubrication: forced lubrication via gear pump, special paper cartridge -type filters, lubricant cooling via heat exchanger on most versions.

3.3. Engine electrical system

The engine electrical system is 12 volt or 24 volts DC, negative ground/earth. This system includes an electric engine starter, a battery (item 4) and a battery charging alternator (item 5). For 12 volts electrical system one battery is given. For 24-volt system two lead-acid batteries are given. Other types of batteries may be fitted if they were specified.

3.4. Cooling system

The engine cooling system is water cooled. The water cooled system is comprised of a radiator (item 6) a pusher fan and thermostat. The alternator has its own internal fan to cool its components.

3.5. Synchronous alternator

This is a horizontal axle alternator (synchronous three phase), on rolling bearings, It is self-ventilated within the room with low-loss silicon-sheet stator bundle, and an electrolytic copper winding with class H insulation.

The output electrical power is normally produced by a screen protected, drip-proof, self-exciting, self-regulating, brushless alternator. (Item 7) Which is fine tuned to the output of this generating set. Mounted on top of the alternator is a sheet steel terminal box (item 8).

Normally, the voltage imbalance capability is 1%, but if generator operation needs to be synchronous, this data should be reduced to 0.5%.

3.6. Coupling

Engine and alternator are firmly joined by a coupling cone that guarantees the proper assembly. If Mono-support machines are used, a special flexible disk is used in place of a flexible coupling.

3.7. Fuel tank and base frame

The engine and alternator are coupled together and mounted on a heavy duty steel base-frame (Item 9). This base frame includes a fuel tank (Item 10) with capacity of approximately 8 hours operation under variable loads. The tank is complete with filling cap and fuel level gauge, and it is connected, by flexible joints, to the intake piping and to the overflow piping containing fuel from the injector drain. High power gen-set's fuel tank is separate from gen-set.

3.8. Vibration isolation

The generating set is fitted with vibration isolators (Item 11) which are designed to reduce engine vibration being transmitted to the foundation on which the generating set is mounted. These isolators are fitted between the engine /alternator feet and the base frame.

3.9. Silencer and exhaust system

Exhaust gases from the turbocharger are dischar-

ged toward atmosphere through a silencer. These should be vented as high as possible to prevent them from re-entering the engine via the charge air intake and polluting the radiator fins.

It is important to note that the turbocharger nozzles must always be free of loads. A stainless steel exhaust compensator is delivered with generator set. Exhaust lines of different engines shall not be mixed in a common stack, but should be routed separately in individual ducts and be enclosed within a chimney.

Suitable material is carbon steel sheet, and recommended calculation temperature is 550°C. A permanent means of drainage for rain and condensate shall be provided to prevent water from entering the silencer or the engine. An exhaust silencer is provided, shipped loosely, for installation with the generating set. The silencer and exhaust system significantly reduces the amount of noise emitted by the engine and directs exhaust gases through safe outlets.

The exhaust silencer is made of a carbon steel receiver and contains a sound attenuator and wave de-phasing system made of perforated steel sheet and heavy rock wool. It is asbestos-free. The exhaust silencer is delivered in two configurations with one being industrial attenuation and the other being residential attenuation. Please check with manufacturer for any special type one.

3.10. Control system

One of several types of control systems and panels (item 12) may be fitted to control the operation and output of the set and also protect the set from possible malfunctions. Section 15 of this manual provides detailed information on these systems and will aid in the identification of the control system fitted on the generating set.

4. INSTALLATION, HANDLING AND STORAGE

4.1 .General

Once the size of the generation set and any associated control systems of switchgear have been established, plans for installation can be prepared. This section discusses factors considered important for the effective and safe installation of the generating set.

4.2 .Canopies

Installation and handling is simplified when the generating set has been equipped with a canopy. The canopy also gives protection from the elements and protection from unauthorized access.

4.3. Moving the generating set

The generating set base frame is specifically designed for ease of moving the set. Improper handling can seriously damage components.

Using a forklift, the generating set can be lifted or carefully pushed/pulled by the base frame directly using the forks. Attention: When using a forklift to push the unit, it is necessary to use wood between the forklift and the base to distribute the load and prevent damage.

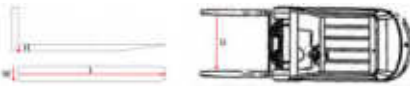

Figure 4.1. Using a forklift to transport the generator set

No	Unit weight	Suggested Forklift	Suggested Fork tooth size				Suggested Forklift Fork tooth spacing
			L/mm	W/mm	H/mm	D/mm	
1	0-3000KG	3T	≥1200	<129	<55	0-815	
2	3001-7000KG	7T	≥1200	<170	<65	0-1540	

Table 4.1

When using a crane to lift the unit, the following precautions should be taken:

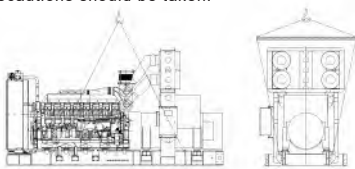

Figure 4.2. Lifting generating set by using a winch

WARNING

! Never lift the generating set by attaching rigging to the engine or alternator lifting lugs.

! Ensure the lifting rigging and supporting structure is in good condition and is suitably rated.

! Keep all personnel away from the generating set while it is suspended.

! If the generating set is going to be lifted, it should be lifted by the lifting points fitted on canopied sets and most open sets.

! Please confirm the content of the lifting label before lifting, if there are any questions please contact the manufacturer.

4.4. Location

In order to start consideration for the possible layouts at a site, the following criteria must first be determined:

-The total area available and any restrictions within that area (i.e. buried or overhead services)

-A forced ventilation system is required for the equipment, which draws sufficient cooling and aspiration air into the room at the back of the alternator and discharges the air from the front of the engine. Depending upon the layout of the building, it may be necessary to install additional ductwork to achieve the airflow required.

-The access into the building, initially for the delivery and installation of the equipment, and afterwards for servicing and maintenance of the equipment.

-Protection from the elements such as rain, snow, sleet wind-driven precipitation, flood water, direct sunlight, freezing temperatures, or excessive heat.

-Protection from exposure to airborne contaminants such as abrasive or conductive dust, lint, smoke, oil mist, vapors, engine exhaust fumes, or other contaminants.

-Protection from the impact of falling objects

such as trees or poles, from motor vehicles, or from lift trucks.

-Clearance around the generating set for cooling and service access: at least 1 meter around the set and at least 2 meter headroom above the set.

-Access to move the entire generating set into the room. Air inlet and outlet vents can often be made removable to provide an access point. Access to unauthorized personnel should be limited.

-If it is necessary to locate the generating set outside of the building, the generating set should be enclosed in a canopy. A canopy is also useful for temporary installations inside or outside of the building.

4.5. Base and foundation

Note: Special foundations are unnecessary. A level and sufficiently strong concrete floor is adequate. The responsibility for the foundation (including seismic considerations) should be placed with a civil or structural engineer specializing in this type of work.

Major functions of a foundation are to:

Support the total weight of the generating set. Considering the vibration by the generating set, it should be isolated from surrounding structures.

To support the structural design, the civil engineer will need the following details:

- The plant's operating temperatures.
- The overall dimensions of the proposed foundation mass.
- The mounting and fixing arrangements of the generator bed-frame.

Concrete Foundations:

The foundation will require at least seven days between pouring the concrete and mounting the

generating set to cure. It is also essential that the foundation be level, preferably within 0.5° of any horizontal plane and should rest on undisturbed soil.

The following formula may be used to calculate the minimum foundation depth:

$$t = \frac{k}{d \times w \times l}$$

t=thickness of foundation in m

k=net weight of set in kg

d=density of concrete (take 2403kg/m³)

w=width of foundation in (m)

l=length of foundation in (m)

The foundation strength may still vary depending on the safe bearing capacity of supporting materials and the soil bearing load of the installation site. Therefore, reinforced gauge steel wire mesh, reinforcing bars, or some equivalent may be required.

Vibration isolation

Each generating set is built as single module with the engine and alternator coupled together through a coupling chamber. This chamber utilizes resilient mounting to form one unit of immense strength and rigidity. This provides both accuracy of alignment between the engine and alternator and damping of engine vibration. This reduces the need for heavy concrete foundations that would normally be used to absorb engine vibrations so that all the generator required is a level concrete floor to take the distributed weight of the unit.

Foundation

A reinforced concrete pad provides a rigid support to prevent deflection and vibration. Typically, the foundation should be 400mm more than the width and length of Gen-set. The ground or floor below the foundation should be properly prepared and structurally suited to carry the weight of the

foundation pad and the generating set. (If the generating set is to be installed above the ground floor, the building structure must be able to support the weight of the generating set, fuel storage, and accessories). If there is a chance that moisture will accumulate on the floor such as in a boiler room, the pad should be raised 150-200mm above the floor. This will provide a dry footing for the generating set and for those who connect, service, or operate it. It will also minimize corrosive action on the base-frame.

Leveling

A poor foundation may result in unnecessary vibration of the gen-set.

4.6. Room design guidance notes

4.6.1. Room size allowance

The dimensions as indicated in Figure 4.5 A & B allow for good maintenance/escape access around the generator. Ideally, a minimum distance of 1 meter should be allowed from any wall, tank or panel within the room.

4.6.2. Inlet and outlet attenuators with weather louvers

The inlet and outlet attenuators should be installed within a frame. The attenuators should be fitted with weather louvers with a minimum of 50% free area, good airflow profile, and afford low restriction airflow access.

The weather louvers should have bird/vermin mesh screens fitted on the inside, but these screens must not impede the free flow of cooling and aspiration air. The outlet attenuator should be connected to the radiator ducting flange with a heat and oil resistant flexible connection.

4.6.3. Combustion air inlet

Air for engine combustion must be as clean and as cool as possible, normally, this air can be drawn from the area surrounding the generating set via the engine-mounted air filter. However, in

some cases due to dust, dirt, or heat, the air around the set is unsuitable. In these cases, an inlet duct should run from the source of clean air (outside the building, another room, etc.) to the engine –mounted air filter. Do not remove the air filter and mount it at a remote location as this can increase the possibility of dirt leaking through the ductwork and into the engine inlet.

4.6.4. Exhaust systems

The exhaust systems shown on the layout drawings are supported by the ceiling. Should the building construction be such that the roof supports are unable to support the exhaust system, a floor standing steel exhaust stand will be needed. Exhaust pipes should terminate at least 2.3m above floor level to make it reasonably safe for anyone passing or accidentally touching.

It is recommended that stainless steel bellows be fitted to the engine exhaust manifold followed by rigid pipe work to the silencer.

It is good installation practice for the exhaust system within the generator room to be insulated with a minimum of 50 mm. Of high-density, high-temperature mineral insulation covered by aluminum over clad. This reduced the possibility of operator bum injury and reduces the heat being transferred to the operating generator room.

4.6.5. Cooling and ventilation

The engine, alternator, and exhaust pipes radiate heat which may result in temperatures high enough to adversely affect the performance of the generating set. It is therefore important that adequate ventilation is provided to keep the engine and alternator cool. Proper air flow, as shown in Figure 4.4., requires that the air comes in at the alternator end of the set, passes over the engine, through the radiator, and out of the room via a flexible outside, the fan will tend to draw the hot

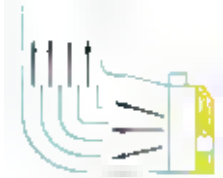

Figure 4.3. Directing the air thrown from the radiator with deviating wings.

air around and back through the radiator reducing the cooling effectiveness.

Sharp corners on the radiator hot air out let channel or its chimney must be avoided. Some rearrangements to turn thrown air should be done. (Figure 4.3. and 4.4.).

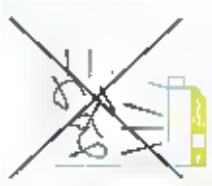

Figure 4.4. Weak ventilation

The air inlet and outlet openings should be large enough to ensure free flow of air into and out of the room. As rough guide the openings should each be at least 1.5 times the area of the radiator core.

Both the inlet and outlet openings should have louvers for weather protection. These may be fixed, but preferably, should be movable in cold climates so that while the generating set is not operating the louvers can be closed. This will allow the room to be kept warm which will assist with starting and load acceptance. For automatically starting generating sets, If the louvers are movable, they must be automatically operated. They should be programmed to open immediately upon starting the engine.

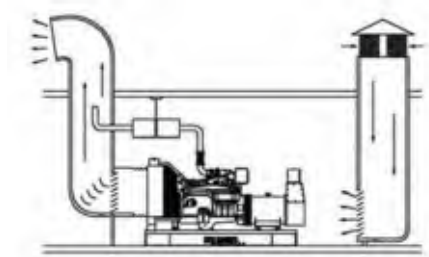

Figure 4.5. Air ventilation

4.6.6. Cable systems

The layout drawing assumes that the change-over switch-gear is external to the generator room and located in the power distribution room. Specific project requirements can affect this layout.

The power output cables from the generator output breaker to the distribution panel must be a flexible type. The flexible power cables as installed should be laid up in trefoil, placed on support trays/ladder rack in the trench with the recommended inter-spacing, and segregated from the system control cables.

The cables should be correctly supported and rated for the installation/ambient conditions.

The flexible single core power cables, when entering any panel, must pass through a non-ferrous gland plate.

4.6.7. Change – over panels

Should the change-over panel with in the generator room.

For change-over cubicles rated up to 400 Amp, rating the wall mounting panel of a maximum depth 350mm can be mounted directly above the cable trench in the side. For change-over cubicles from 800 Amp and above a floor standing panel is used which needs additionally allocated space. A minimum of 800mm for rear access should be allowed.

4.6.8. Doors

Doors should always open outwards. Make any necessary allowance for the generator to be moved into the room by using double doors at the attenuator space.

4.6.9. Inlet and outlet louvers

The inlet and outlet weather louvers should be installed within a frame with a minimum 50% free area, good airflow profile, and low restriction airflow access.

The weather louvers should have bird/vermin mesh screens fitted on the inside, but must not impede the free flow of cooling and aspiration air.

The outlet weather louver should be connected to the radiator ducting flange with a heat and oil resistant flexible connection.

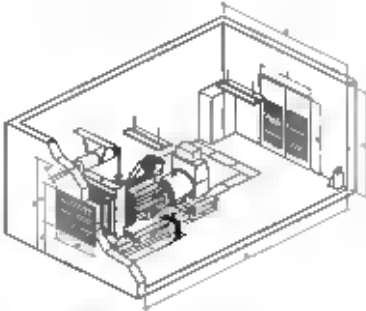

Figure 4.6. Generating set room

4.7. Bellows

The purpose of a flexible connection is to allow for engine displacement, to allow for thermal expansion of the system, to facilitate alignment of the engine with the pipes (exhaust, cooler), and prevent vibration transmission.

Some bellows with long bolts are same function, but the long bolts are used for adjusting bellows length and easy connection. For some generator

sets, we need disassemble radiator or silencer system for shipment, but please make sure all the long bolts must be removed from generator sets after mounted in site.

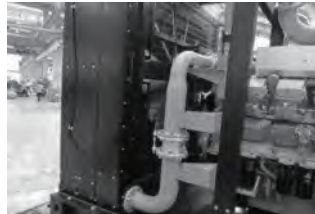
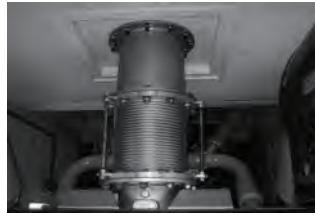
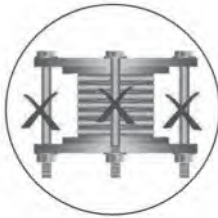

Figure 4.7. Bellows

⚠ After the gen-set is installed in site, please make sure user must remove all long adjustment bolts of bellows before starting the gen-set.



5. FUEL SYSTEM

5.1. General

Depending upon the specific site layout, the fuel can be supplied to the engine either from:

1. The sub-base fuel tank located under the generating set.
2. An intermediate daily service tank located within the plant room or generator enclosure which will be automatically refilled from a bulk storage tank.
3. Directly from the bulk storage tank provided that the outlet connection from this tank is at least 500mm higher than the base upon which the generator is mounted.

It is very important that the fuel oil purchased for use in any engine be as clean and water-free as possible. Dirt in the fuel can clog injector outlets and ruin the finely machined precision parts in the fuel injection system. Water in the fuel will accelerate corrosion of these parts.

5.2. Diesel fuel recommendations

The following fuel oil specification is typical

Diesel Fuel Recommended Physical Properties Specifications.

Viscosity(ASTM D445)	1.3 to 5.8 centi strokes(1.3 to 5.8mm per second) at 40°C (104°F)
Cetane Number(ASTM D613)	40 Minimum above 0°C (32°F) 45 Minimum above 0°C (32°F)
Sulphur Content (ASTM D129 or 1552)	Not to exceed 0.5 mass percent
Water and Sediment (ASTM D1796)	Not to exceed 0.05 volume percent
Density (ASTM D287)	42 to 30 API GRAVITY AT 60°F (0.816 to 0.876 g/cc at 15°C)
Cloud Point (ASTM D287)	6°C (10°F) below lowest ambient temperature at which the fuel is expected to operate
Ash(ASTM D482)	Not to exceed 0.02 mass percent(0.05 mass percent with lubricating oil blending)
Acid Number (ASTM D664)	Not to exceed 0.1 Mg KOH per 100 ML.
Lubricity	3100 grams or greater

Table 5.1.

Diesel fuel property definition

Ash – Mineral residue in fuel. High ash content leads to excessive oxide build-up in the cylinder and/or injector. **Cetane Number** – Ignitability of fuel. The lower the cetane number is, the harder it is to start and run the engine. Low cetane fuels ignite later and burn slower. This could lead to explosive detonation by having excessive fuel in the chamber at the time of ignition. In cold water or with prolonged low loads, a higher cetane number is desirable.

Cloud and pour points – The pour point is the temperature at which the fuel will not flow. The cloud point is the temperature at which the wax crystals separate from the fuel.

The pour point should be at least 6°C (10°F) below the ambient temperature to allow the fuel to move through the lines. The cloud point must be no more than 6°C (10°F) above the pour point so the wax crystals will not settle out of the fuel and plug the filtration system.

Sulfur – The amount of sulfur residue in the fuel. The sulfur combines with the moisture formed during combustion to form sulfuric acid.

Viscosity – Influences the size of the atomized droplets during injection. Improper viscosity can lead to detonation, power loss, and excessive smoke. Fuels that meet the requirements of ASTM or 2.0 diesel fuels are satisfactory with fuel systems.

5.3. Base fuel tank

Up to 1000 kVA generating sets can be supplied with or without base fuel tanks. The room height allows for this feature.

Recommended room layout drawings incorporate base fuel tanks on the generators.

This provides a self-contained installation without the addition of external fuel lines, trenches, or fuel transfer pumps. Generators with base tanks are delivered fully connected and ready to run.

5.4. Bulk storage tanks

The purpose of the fuel-supply system is to store an adequate quantity of fuel to suit the application for which the system is intended. The bulk storage tanks should be sized accordingly.

The filling of the tanks will be by means of a fill connection housed in a suitable, lockable, cabinet located so as to permit easy access by delivery tanker. This cabinet may also house a contents gauge and an overflow alarm connected to the float switch inserted into a manhole on the tank.

5.5. Without intermediate fuel tank (Fig.5.1.)

The simplest arrangement would be supply the engine directly from the bulk storage tank and return the infector spill directly to this tank. A typical arrangement for this is shown in Fig.5.1. The principle limitations of this method are: In order to gravity feed the engine, the outlet from the bulk storage tank must be a minimum of 600 mm above the generator plinth level; The pressure drop of the spill return pipe work must not exceed that detailed in the Engine Data

sheet; The supply pipe work from the bulk storage tank to the engine must be sized to allow the total volume of fuel required by the engine to flow under gravity.

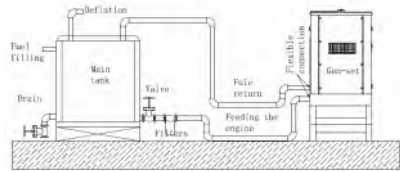

Figure 5.1. Without Intermediate Fuel Tank

5.6. With intermediate fuel tank (Fig.5.2)

Where it is not possible to supply the engine direct from the bulk tank due to site constraints, an intermediate tank can be located within the plant room/generator enclosure which supplies fuel directly to the engine.

This type of system can be further enhanced by the addition of the following optional items of equipment:

1. An automatic duplex fuel transfer pump and primary filter system arranged to start the standby pump should the duty pump fail. The transfer pump(s) must be sized to cater for the total fuel required by the engine, i.e. fuel consumed and the spill return volumes (Fig.5.2.)
2. A fusible link operated dead weight drop valve designed to cut off the supply of fuel to the intermediate tank and to transmit a signal in the vent of fire;
3. A fusible, link operated, dump valve arranged to dump the contents of local tank back into the bulk tank in the event of a fire within the generator enclosure.

The connection details for these additional items of equipment are indicated. See Fig. 5.2.

in the engine cycle away from the injectors and back to either the fuel storage tank or the day tank. The heat from the excess fuel is dissipated in the tank.

Caution: Never run a fuel return line directly back to the engine fuel supply lines. The fuel will over-heat and break down.

The fuel return lines should always enter the storage or day tank above the highest fuel level expected. The fuel return line should never be less than one pipe size smaller than the fuel supply line.

WARNING

- The fuel must be clean and must not contain any water.
- Do not use galvanized pipe for fuel pipe.
- When the engine stops, there should not be any gravitational free flow in the fuel pipes towards in the direction of the engine.
- The fuel temperature is a critical factor for appropriate working conditions of the engine. Normally, fuel temperatures above 71 C, due to expansion of the fuel, will decrease the engine output power. Please check engine datasheet for fuel temperature requirement of every engine.
- In fuel system lines, using the water filter separators will prevent the injectors and fuel pump and it is also useful for healthy working of the engine.

1. Fill cabinet with overfill alarm and gauge
2. Tank fills line
3. Vent line
4. Contents gauge
5. Bulk storage tank
6. Sludge drain
7. Bund tank
8. Outlet valve
9. Supply line to day tank
10. Electric fuel transfer pump
11. Electrical fuel shut off valve
12. Optional band
13. Day tank incorporated in base frame
14. Float Control switches
15. Manuel fill and vent
16. Level gauge
17. Drain
18. Leakage alarm unit (optional)
19. Fuel filter
20. Engine fuel pump

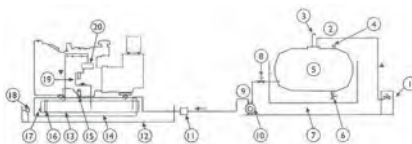

Figure 5.3. Typical fuel installation using a base tank fed from a bulk tank

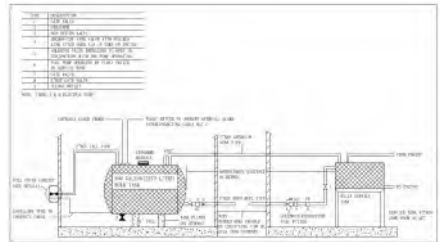

Figure 5.4. Suggested Installation for Bulk and Set Tanks

Generating Set Stand by Power	Maximum Fuel Pipe Length (m)	Maximum Vertical Height (m)	Maximum Pipe Fittings Quantity (m)	Recommended Pipe Diameter (inch)
40-800	6	0.9	6	1"
800-1500	6	0.9	6	1 1/2"
1500-2200	6	0.9	6	2"

Table 5.2. Recommendations for fuel piping

6. COOLANT TREATMENT

6.1. General

The engine cooling system is subject to rust and cavitation attacks. To minimize the severity of this condition, an anti-corrosive agent can be added to totally clean and limpid coolant water.

An anti-freeze solution is also required to prevent freezing of the coolant in the cold weather.

6.2. Engine coolant

The coolant should be clean and free from any corrosive chemicals such as chlorides, sulphates, or acids. It should be kept slightly alkaline with a pH value ranging from 8.5 to 10.5 generally, any water that is suitable for drinking can be used, with treatment, as described below.

Protection against corrosion

Supplemental Coolant Additive is required to protect the cooling system from fouling, solder blooming, and general corrosion.

The use of antifreeze is also recommended as DCA4 concentrations are dependent upon the presence of antifreeze. Antifreeze also interacts with DCA4 to provide greater corrosion and protection against cavitation.

Procedure for treating coolant

1. Add the required amount of water to mixing container and dissolve in the required quantity of DCA.
2. Add the required amount of antifreeze, if used, to the water solution and mix thoroughly.
3. Add the coolant to the cooling system.

Cold weather protection

Antifreeze must be added to the coolant where there is any possibility of freezing to protect the engine from damage due to coolant freezing.

A 50% antifreeze / 50% water mixture is recommended because DCA4 concentrations are dependent upon the presence of antifreeze. The dosage of DCA4 must be increased to higher concentration if antifreeze is not added to the coolant. Low-silicate antifreeze is recommended.

6.3. Engine warming

There are thermostatically controlled water jacket heaters operating from the main's supply. There are fitted into the cooling system. And they maintain the temperature of the coolant in cold weather.

A heater alone, fitted in the radiator, will not be adequate for starting or preventing freezing, so an antifreeze mixture should be used.

Warning: The valves on the heater in/out pipe must be turned on all the times to avoid dry-burning, after installation it has to be checked. Only it can be turned off during maintenance or replacement.

7. EXHAUST SYSTEM

7.1. Sizing

An exhaust system should be designed to dispel the exhaust gases to atmosphere at the nearest convenient point in an installation. The length of the run and the number of changes in direction should be kept to a minimum.

The calculation of the effect on the back pressure is based upon the restriction through the straight lengths of pipe, the bends, and the silencers. The smaller the bore of the pipe is, the greater its length is, and the more times it changes its direction all increase the resistance to flow.

The back pressure must meet engines limit data! Take an estimate of the size of the pipe by starting with the bore of the exhaust flange off the manifold and increasing the size by 1" for each 20 ft length or 3 x 90 bends.

7.2. Routing

Once the final size and route of the pipe work and the silencer have been established, the exhaust route can be determined if the following factors are taken into consideration:

A flexible bellows unit must be fitted on the engine connection to allow the engine to move on its mountings; If the silencer is to be located within the plant room, due to its physical size and weight, it needs to be supported from the floor;

It may be necessary to install expansion joints at each change of direction to compensate for the thermal growth in the pipe during operation;

The inner radius of a 90° bend should be 3 times the diameter of the pipe See Figure. 7.1.

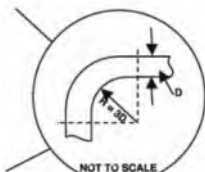

Figure 7.1. Exhaust bend and radius

The primary silencer should be mounted as close as possible to the engine;

The termination point should not be directed at combustible materials/structures, into hazardous atmospheres containing flammable vapors, where there is a danger that the gases will re-enter the plant room through the inlet air vent, or into any opening that leads to another building in the vicinity.

All rigid pipe work should be installed in such a manner that the engine's exhaust outlet is not stressed. Pipes should be routed so that they are supported by fixtures to the building fabric or by existing structural steelwork where such methods are acceptable;

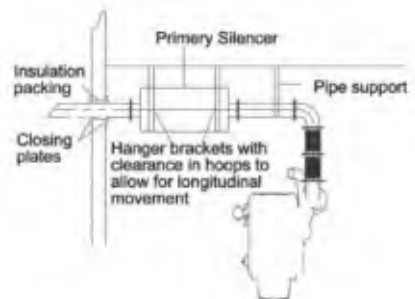

Figure 7.2. Exhaust system

WARNING:

The silencer which need to be mounted at site (such as container or canopy type gen-sets) must be checked about sealing performance of all flanges by professional engineer, to ensure that the exhaust system does not leak smoke and water. If there are any questions, please contact manufacturer.

8. LUBRICATING OIL

The oil system of diesel engine is one of the most important elements of the engine. Proper engine maintenance (this subject includes oil change periods, filter change periods, paying attention about selecting the true type of oil) significantly prolongs the life cost of the engine.

8.1. Oil performance properties

The American Petroleum Institute (API) the American Society for Testing and Materials (ASTM) and Society of Automotive Engineers (SAE) has developed and preserved a system in order to classify the lubrication oils for their performance categories,

8.2. Lubrication recommendations for engine

Aksa recommends that high quality multi-grade SAE 15W/40 high service engine oil in diesel engines are used. At ambient temperatures above -15°C is 15W40.

The minimum API oil quality levels recommended for use is CH / CI-4, CH or CI-4 can be used in areas where CF4 oil is not yet available, but the oil interval must be reduced API CA, CB, CC, CD, CE, CG4 categories not recommended, do not use.

8.3. Lubricating oil replace

Normally lubricating oil changes according maintained chat , but for new engine or overhauled engine, lubricating oil including oil filter need to be changed after running 50 hours.

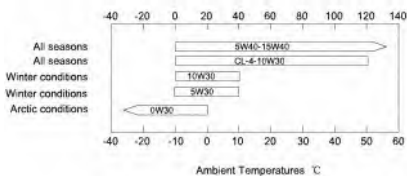

Figure 8.1. Recommended SAE Oil Viscosity Grades vs. Ambient Temperatures

9. ELECTRIC STARTING SYSTEMS

Electric starting systems are generally used on all gen-sets. The power source for electric starting systems is a 12 or 24 VDC battery system. The starting voltage is determined by engine size with 24 VDC being used for larger engines to reduce starting current and, hence, the cable size. Control of starting is performed via a start solenoid which is controlled by the gen-set control system.

9.1. Battery systems

Batteries are of two types - lead acid and NiCad. Lead acid batteries are generally used, being the least expensive. NiCad batteries are used where longer life, etc., is required.

When preparing to start the gen-set, place the battery onto battery support located on the base frame. Next, connect the battery cable to the battery. First connect positive pole, then connect the negative pole. When removing the battery, always remove the negative battery cable first.

9.2. Maintenance batteries

WARNING

-Do not smoke or allow sparks, flame or other sources of ignition around batteries Hydrogen gas generated by charging batteries is explosive.

-Wear an acid resistant apron and face shield or goggles when servicing the batter. If electrolyte is spilled on skin or clothing, flush immediately with large quantities of water.

-Take out the metallic things in your wrist and protect your wrist and hand.

-Disconnect the battery negative (earth) lead first and reconnect last.

-Always ensure the battery charging is carried out in a well-ventilated area.

-The starting batteries should be located as close as possible to the generating set while

still being accessible for servicing. This will prevent electrical losses.

9.3. Battery maintenance

- Keep the top of the battery and its terminals clean.
- Cover the battery terminals and its connections with Vaseline.
- Tighten the terminals until they do not move freely. Do not over tighten.
- Check the electrolyte level periodically. It should be 10mm above the plates.
- Periodically check for any abrasions on the alternator belt and also check the tension. Compare the belt tension to the producer's recommendations and adjust if required.
- Periodically check to make sure that the battery is charged.

9.4. Maintenance free batteries

Ensure that all battery connections are correct and batteries are always charged.

9.5. Starting aids

It is customary to keep coolant temperatures at or above 40 C in order to promote quick starting on an emergency generating plant. Thermostatically controlled immersion heaters, deriving their supply from the primary source of power, are fitted into the engine cooling system to provide this heating.

10. ELECTRICAL CONNECTION

Only full qualified and experienced electrical technicians should carry out electrical installation, service, and repair work.

WARNING:

-Make electrical connections in compliance with all relevant Electrical Codes, Standards, or other requirements.

10.1. Cabling

Due to movement of generating sets on their vibration mounts, the electrical connection to the set should be made with flexible cable.

The cable must be suitable for the output voltage of the generating set and the rated current of the set. In determining the size, allowances should be made for ambient temperature, method of installation, proximity of other cables. etc.

All connections should be carefully checked for integrity. The current carrying capacity of power cables are given in last section Technical Information table and the cable cross sections which must be used according to the generating set power are given in last section table. On the other hand, there is one more important point to consider while selecting cable cross sections. If the distance between load and generator is too long, the voltage drop on the load side may be too high at the transient current duration. The voltage drop across a cable can be determined as follows:

$$e = \frac{\sqrt{3} \times L \times I \times (R \cos\phi + X \sin\phi)}{1000}$$

e = Voltage drop (V)

I = Rated current (A)

L = Length of conductors (m)

R = Resistance (Ω /km to VDE 0102)

X = Reactance (Ω /km to VDE 0102)

10.2. Protection

The cables connecting the generating set with the distribution system are protected by means of a circuit breaker to automatically disconnect the set in case of overload or short circuit.

10.3. Loading

When planning the electrical distribution system, it is important to ensure that a balanced load is presented to the generating set. If loading on one phase is substantially higher than the other phases, it will cause over heating in the alternator windings, imbalance in the phase output voltage, and possible damage to sensitive 3-phase equipment connected to the system. Ensure that no individual phase current exceeds the current rating of the generating set. For connection to existing distribution system, it may be necessary to reorganize the distribution system to ensure these loading factors are met.

10.4. Power factor

The power factor (Cosφ) of the connected load should be determined. Power factors below 0.8 lagging (inductive) can over load the generator. The set will provide its kilowatt rating and operate satisfactorily from 0.8 lagging to unity power factor (1.0) Particular attention must be given to installations with power factor correction equipment such as capacitors to ensure that a leading power factor is never present. This will lead to voltage instability and may result in voltage surges that may damage equipment. Generally, whenever the generating set is supplying the load, any power factor correction equipment should be switched off.

Cable Section mm ²	25 °C at Air		40°C at Air		
	Multiple Core	Multiple Core	Multiple Core	Multiple Core	H007RN-F
2.5	36	25	22	25	21
4	46	34	30	33	28
6	58	44	38	42	36
10	77	60	53	57	50
16	100	80	71	76	67
25	130	105	94	101	88
35	155	130	114	123	110
50	185	160	138	155	138
70	230	200	176	191	170
95	275	245	212	288	205
120	315	285	248	267	245
150	355	325	283	305	271
185	400	370	322	347	310
240	465	435	380

Table 10.1. Current carrying capacity of power cables (PVC –isolated YVV, NYV, 0.6/1 kV, VDE and TSE norms)

10.5. Grounding/Earthing requirements

The frame of the generating set must be connected to an earth ground. Since the set is mounted on vibration isolators, the ground connection must be flexible to avoid possible breakage due to vibration. Ground connection cables or straps should have at least full load current carrying capacity and meet applicable regulations.

10.6. Insulation test

Before starting the generating set after installation, test the insulation resistance of the windings. The Automatic Voltage Regulator (AVR) should be disconnected and the rotating diodes either shorted out with temporary links or disconnected. Any control wiring must also be disconnected.

A 500V Megger or similar instrument should be used.

Disconnect any grounding conductors connected between neutral and earth and meg an output terminal to earth.

11. ACOUSTIC SILENCING

Controlling the amount of noise output by a generating set is becoming very important in most installations. There is a variety of components available to control the noise level.

WARNING

Ear protection must be worn when operating or working around an operating generating set.

11.1. Exhaust silencers

As discussed in Section 3.9. The exhaust silencer will decrease sound level from the engine.

11.2. Canopies

Section 4.2. Discusses sound attenuating canopies that lower the noise level of the entire generating set.

11.3. Other sound attenuation

For installation in buildings, there are other types of equipment such as acoustic louvers, splitter vents, and fan silencers as well as sound absorbing wall coverings that can be used to reduce the noise levels of generating sets.

12. TOWING (Mobile Generating Sets)

12.1. Preparing to Tow

Inspect all components of the coupling equipment on the towing vehicle and the generating set for defects such as excessive wear, corrosion, cracks, and bent metal or loose bolts.

Inspect tyres for condition and proper inflation. Check that all tail lights, if equipped, are operating properly and that all reflectors are clean and functional.

12.2 Towing

Whenever towing a mobile generating set, remember that maneuverability and stopping distance will be affected by the e trailer.

WARNING

! When mobile generating set, observe all Codes, Standards or other regulations and traffic laws. These include those regulations specifying required equipment and maximum and minimum speeds.

! Do not permit to ride on the mobile generating set.

! Do not permit personnel to stand or ride on the Drawbar or to stand or walk between the generating set and towing vehicle.

! Avoid gradients and avoid potholes, rocks or other obstructions and soft or unstable terrain.

! Ensure the area behind and under the mobile set is clear before reversing.

12.3. Parking

Park the gen-set on a dry level and horizontal area that can support its weight. If it must be located on a slope, park it across the grade so that it does not tent to roll downhill. Do not park the set on grades exceeding 10 degree. Please confirm with manufacturer if the slope gradient is more than 10 degrees.

13. STORAGE

Long-term storage can have detrimental effects on both the engine and alternator. These effects can be minimized by properly preparing and storing the generating set. Need to operate the stock genset 5-10 minutes every 2-3 months.

13.1. Engine storage

The engine should be put through an engine "preservation" procedure that includes cleaning the engine and replacing all the fluids with new fluids or preserving fluids.

13.2. Alternator storage

When an alternator is in storage, moisture tends to condense in the windings. To minimize condensation, store the generating set in a dry storage area. If possible use space heaters to keep the windings dry. After removing the generating set from storage, perform an insulation check as discussed in Section 10.6.

13.3. Battery storage

While the battery is stored, it should receive a refreshing charge every 4 weeks up to a fully charged condition..

13.4. Standby gen-set

The gen-set should operating every month to lubricating main parts and check if have any leakage.(smoke, coolant,oil)

After the installation is completed and before the gen-set is started, the connection of each component must be checked by professional engineer. If there are any questions, please contact manufacturer.

14. GENERAL PRECAUTIONS AND CONTROLS WHICH MUST BE DONE BEFORE STARTING UP THE GENERATING SET.

- Make a general visual inspection on the engine and alternator. Check to see if there are any breaks, cracks, indentation, leaks, or looseness. If any of these exist, DO NOT operate the gene-rating set before making the necessary repairs.
- Take out foreign materials such as keys, tools, cleaning wool, papers, etc. on the engine and the alternator.
- Check the fuel level in day tank. Refill with fuel if it is low.
- Check the oil level on the dipstick. Refill with an appropriate oil if it is low. Oil level should normally be close to the maximum level line.
- Look at the water level by opening the radiator tap. If it is inadequate, add more water. Water level should be approximately 1-8" lower than the water filling neck.
- Engine cooling water must include antifreeze according to the coolest weather conditions in the area.
- A mixture of 50% antifreeze and 50% water provides a good protection in all areas.
- Inspect the radiator air outlet hood, open if clogged, and clear away all obstructions in front of the air outlet.
- Check the air filter gauge. Clean or replace the air filter, if necessary
- Make sure that opening is not obstructed.
- Make sure that the generating set can easily take air from the environment.
- Check the battery connection cables. Take care to tighten any loose battery terminals with the proper size tool and cover with any battery terminal coating substance. In order to keep

15. GENERATING SET CONTROL SYSTEMS

clean and avoid oxidation and corrosion of terminals.

- Ensure that the circuit breaker outlet switch is in the OFF position.
- Make sure that the emergency stop button is not pressed.
- Ensure the fan belt is not cracked, the belt is perpendicular to the pulley and in the pulley groove;
- Ensure the battery is fully charged. If the battery voltage is below 12.6V, please charge it immediately, or the battery cover is equipped with an indicator, which may indicate state of charge. When the indicator becomes green, the battery can work normally; when indicator turns black, the battery should be charged in time, and when indicator turns white, it should be replaced immediately. Parked batteries need to be recharged every 3---6 months. It is recommended to replace the batteries between 1 and 2 years.
- For any gen-sets which have been stored for six months or above from the shipment date, it is the customer's responsibility to conduct a warm-up operation before restarting, that is, to run the gen-set under low speed by cranking it for several times or running it under idle speed, for a sufficient duration to fully lubricate all the components before applying load and increasing the engine speed to the rated speed.
- It is the customers' responsibility to inspect the heat radiating system before first starting a gen-set, that is, to check the radiator for any leaks.

For any gen-sets with fan(s) mounted on a radiator, it is the customers' responsibility to check if the bearing(s) of fan(s) has become loosen, if the lubricating oil is sufficient, and pre-lubricate the bearing(s) before first starting the gen-set or periodically lubricate the bearing(s) according to the pertinent requirements.

To control and monitor the generating set, an electronic control system has been used. The DSE6120 control system is fitted to less than 220kVA generating sets. The DSE7320 control system is fitted to other generating sets including and more than 220kVA. This control panel provides a means of starting and stopping the generating set, monitoring its operation and output, and automatically shutting down the set in the event of critical condition arising such as low oil pressure or high engine temperature.

Control, supervision and protection panels are mounted on the generator base frame.

These are many fuses inside of the control panel for protection. If a fuse blows, check all related wires. After the problem is resolved, replace the fuse with the appropriate size fuse. DO NOT use a fuse of size other than what was originally in the control panel.

15.1. DSE6120, control system with automatic mains failure

The DSE6120 module controls generating set system. This module has been designed to monitor the mains (utility) supply.



Figure 15.1. DSE6120 Control Module

The DSE6120 is an Auto Mains (Utility) Failure Control Module suitable for a wide variety of single, diesel or gas, gen-set applications.

Monitoring an extensive number of engine parameters, the modules will display warnings, shutdown and engine status information on the back-lit LCD screen, illuminated LEDs and remote PC.

KEY FEATURES

- 4-line back-lit LCD text display
- Multiple display languages
- Five-key menu navigation
- LCD alarm indication
- Customizable power-up text and screen images.
- DSENet® expansion compatibility
- Data logging facility
- Internal PLC editor
- Protections disable feature
- Fully configurable via PC using USB communications
- Front panel configuration with PIN protection
- Power save mode
- 3-phase generator sensing and protection
- 3-phase mains (utility) sensing and protection
- Automatic load transfer control
- Generator current and power monitoring (kW, kvar, kVA, pf)
- Mains (utility) current and power monitoring (kW, kvar, kVA, pf)
- kW overload alarm
- Over current protection
- Breaker control via fascia buttons
- Fuel and start outputs configurable when using CAN
- 6 configurable DC outputs
- 4 configurable analogue/digital inputs
- Support for 0 V to 10 V & 4 mA to 20 mA sensors
- 8 configurable digital inputs
- CAN, MPU and alternator frequency speed sensing in one variant
- Real time clock
- Manual and automatic fuel pump control
- Engine pre-heat and post-heat functions
- Engine run-time scheduler
- Engine idle control for starting & stopping
- Fuel level alarms
- 3 configurable maintenance alarms
- Compatible with a wide range of CAN engines, including Tier 4 engine support

- Uses DSE Configuration Suite PC Software for simplified configuration
- License-free PC software
- IP65 rating (with optional gasket) offers increased resistance to water ingress
- Configurable CAN read & transmitted information.
- 1 alternative configuration.

KEY BENEFITS

- Automatically transfers between mains (utility) and generator for convenience.
- Hours counter provides accurate information for monitoring and maintenance periods
- User-friendly set-up and button layout for ease of use
- Multiple parameters are monitored & displayed simultaneously for full visibility
- The module can be configured to suit a wide range of applications for user flexibility
- PLC editor allows user configurable functions to meet user specific application requirements.

15.2. DSE7320, control system with automatic mains failure

The DSE model 7320 module controls generating set system. This module has been designed to monitor the mains (utility) supply.



Figure 15.2. DSE7320 Control Module

The DSE7320 is an Auto Mains (Utility) Failure Control Module suitable for a wide variety of single, diesel or gas, gen-set applications.

The DSE7320 will also monitor the mains (utility) supply. The modules include USB, RS232 and RS485 ports as well as dedicated DSENet® terminals for system expansion.

Monitoring an extensive number of engine parameters, the modules will display warnings, shutdown and engine status information on the back-lit LCD screen, illuminated LEDs, remote PC and via SMS text alerts (with external modem).

KEY FEATURES

- 4-Line back-lit LCD text display
- Multiple Display Languages
- Five key menu navigation
- LCD alarm indication
- Heated display option available
- Customizable power-up text and images
- DSENet expansion compatibility
- Data logging facility
- Internal PLC editor
- Protections disable feature
- Fully configurable via PC using USB, RS232 & RS485 communication
- Front panel configuration with PIN protection
- Power save mode
- 3 phase generator sensing and protection
- 3 phase mains (utility) sensing and protection (DSE7320 only)
- Automatic load transfer control (DSE7320 only)
- Generator current and power monitoring (kW, kvar, kVA, pf)
- Mains current and power monitoring (kW, kvar, kVA, pf) (DSE7320 only)
- kW and kvar overload and reverse power alarms
- Over current protection
- Unbalanced load protection
- Independent earth fault protection
- Breaker control via fascia buttons
- Fuel and start outputs configurable when using CAN
- 6 configurable DC outputs
- 2 configurable volt-free relay outputs
- 6 configurable analogue/digital inputs
- Support for 0 V to 10 V & 4 mA to 20 mA sensors
- 8 configurable digital inputs
- Configurable 5 stage dummy load and load shedding outputs
- CAN, MPU and alternator frequency speed sensing in one variant
- Real time clock
- Manual and automatic fuel pump control
- Engine pre-heat and post-heat functions
- Engine run-time scheduler
- Engine idle control for starting & stopping
- Fuel usage monitor and low fuel level alarms
- Simultaneous use of RS232 and RS485 communication ports
- True dual mutual standby using RS232 or RS485 for accurate engine hours balancing.
- MODBUS RTU support with configurable MODBUS pages.
- Advanced SMS messaging (additional external modem required)
- Start & stop capability via SMS messaging
- 3 configurable maintenance alarms
- Compatible with a wide range of CAN engines, including tier 4 engine support
- Uses DSE Configuration Suite PC Software for simplified configuration
- license-free PC software
- IP65 rating (with supplied gasket) offers increased resistance to water ingress
- Modules can be integrated into building management systems (BMS) using MODBUS RTU KEY BENEFITS
- Automatically transfers between mains (utility) and generator for convenience.
- Hours counter provides accurate information for monitoring and maintenance periods
- User-friendly set-up and button layout for ease of use
- Multiple parameters are monitored & displayed simultaneously for full visibility
- The module can be configured to suit a wide



range of applications for user flexibility



- PLC editor allows user configurable functions to meet user specific application requirements.



15.3. Operation mode

DSE6120 and DSE7320 can work at manual mode, automatic mode, test mode, details are as follows

15.3.1. manual mode

This button places the module into its **Manual Mode** . Once in **Manual Mode** , the module responds to the **Start**  button to start the generator and run it off load.

To place the generator on load, use the **Transfer to Generator**  button. The module automatically instructs the changeover device to take the mains off load ('Close Mains Output' becomes inactive) and place the generator on load ('Close Generator Output' becomes active (if used)). To place the generator off load, use the **Transfer to Mains**  button. The module automatically instructs the changeover device to take the generator off load ('Close Generator Output' becomes inactive (if used on)) and place the mains on load ('Close Mains Output' becomes active). Additional digital inputs can be assigned to perform these functions.

If the engine is running off-load in **Manual Mode**  and on load signal becomes active, the module automatically instructs the changeover device the changeover device to take the mains off load ('Close Mains Output' becomes inactive) and place the generator on load ('Close Generator Output' becomes active (if used)). Upon removal of the on load signal, the generator remains on load until either selection of the **Stop/Reset Mode**  or **Auto Mode** .





15.3.2. Auto mode



This button places the module into its **Auto Mode** . This mode allows the module to control the function of the generator automatically. The module monitors numerous start requests and when one has been made, the set is automatically started. Once

the generator is available, the mains is taken off load ('Close Mains Output' becomes inactive) and the generator is placed on load ('Close Generator Output' becomes active (if used)).

Upon removal of the starting signal, the module starts the Return Delay Timer and once expired, takes the generator off load ('Close Generator Output' becomes inactive (if used on)) and place the mains on load ('Close Mains Output' becomes active). The generator then continues to run for the duration of the Cooling Timer until it stops. The module then waits for the next start event.

























15.3.3. Test mode



This button  places the module into its **Test Mode** . Once in **Test Mode** , the module responds to the **Start**  button to start the generator. Once the set has started and becomes available, it is automatically placed on load (Close Mains Output becomes inactive and Close Generator Output becomes active (if used)).

The generator remains on load until either the **Stop/Reset Mode**  or **Auto Mode**  is selected.

15.4. Other Push buttons and Starts/ Measurement units

15.4.1. Push buttons

Icon	Description
	<p>Stop / Reset Mode</p> <p>This button places the module into its Stop/Reset Mode . This clears any alarm conditions for which the triggering criteria has been removed. If the engine is running and the module is put into Stop/Reset Mode , the module automatically instructs the generator off load ('Close Generator Output' becomes inactive (if used on)) and place the mains on load ('Close Mains Output' becomes active). The fuel supply de-energies and the engine comes to a standstill. Should any form of start signal be present when in Stop/Reset Mode  the generator remains at rest</p>
	<p>Alarm Mute / Lamp Test</p> <p>This button silences the audible alarm in the controller, de-activates the Audible Alarm output (if configured) and illuminates all of the LEDs on the module's fascia as a lamp test function.</p>
	<p>Start</p> <p>This button is only active in the Stop/Reset Mode , Manual Mode  and Test Mode . Pressing the Start  button in Stop/Reset Mode  powers up the engine's ECU but does not start the engine. This can be used to check the status of the CAN communication and to prime the fuel system. Pressing the Start  button in Manual Mode  or Test Mode  starts the generator and runs it off load in Manual Mode  or on load in Test Mode .</p>
	<p>DSE7320 Menu Navigation</p> <p>Used for navigating the instrumentation, event log and configuration screens.</p>
	<p>DSE6120 Menu Navigation</p> <p>Used for navigating the instrumentation, event log and configuration screens.</p>
	<p>Transfer To Generator</p> <p>The Transfer to Generator  button controls the operation of the generator load switch is only active in the Manual Mode  once the generator is available.</p> <p>'Normal' Breaker Button Control</p> <p>Pressing the Transfer to Generator  button when the Generator is available and off load, the Mains load switch is opened ('Close Mains' becomes inactive) and the Generator load switch is closed ('Close Generator' becomes active). Further presses of the Transfer to Generator  button have no effect.</p> <p>'Alternative' Breaker Button Control</p> <p>Pressing the Transfer to Generator  button when the Generator is available and off load, the</p>

Icon	Description
	Mains load switch is opened ('Close Mains' becomes inactive) and the Generator load switch is closed ('Close Generator' becomes active). Further presses of the Transfer to Generator button opens and closes the Generator load switch ('Close Generator' changes state) and leaves the Mains load switch in the open position ('Close Mains' remains inactive). e).
	<p>Transfer To Mains</p> <p>The Transfer to Mains button controls the operation of the mains load switch and is only active in Manual Mode. 'Normal' Breaker Button Control</p> <p>Pressing the Transfer to Mains button when the Mains is available and off load, the generator switch is opened ('Close Generator' becomes inactive) and the mains switch is closed ('Close Mains' becomes active).</p> <p>Further presses of the Transfer to Mains button have no effect. 'Alternative' Breaker Button Control</p> <p>Pressing the Transfer to Mains button when the Mains is available and off load, the generator load switch is opened ('Close Generator' becomes inactive) and the mains load switch is closed ('Close Mains' becomes active). Further presses of the Transfer to Mains button opens and closes the mains load switch ('Close Mains' changes state) and leaves the generator load switch in the open position ('Close Generator' remains inactive).</p>

15.4.2. Status/Masurement units

Display	Description	Display	Description	Display	Description
L1	Phase	L2	Phase	L3	Phase
L1 - N	Phase-Neutral	L2 - N	Phase-Neutral	L3 - N	Phase-Neutral
L1 - L2	Phase-Phase	L2 - L3	Phase-Phase	L3 - L1	Phase-Phase
BAR	Pressure	Kpa	KPa/Oil Pressure Units	PSI	Pressure
V	Voltage	F	Temperature	Hz	Frequency
A	Amperes	C	Temperature	RPM	Speed
KW	KiloWatts	kVA	Apparent power	Cosp	KW divided by kVA

16. GENERAL PRECAUTIONS AND CONTROLS WHICH MUST BE DONE AFTER STARTING UP THE GENERATING SET

- Check for any abnormal noise or vibration on the generating set.
- Check to see if the exhaust system has any leakage.
- Monitor the generating set operation by means of the control module LCD display. Check the engine temperature and oil pressure. Oil pressure must reach the normal value 10 seconds after the generating set begins operation.
- Monitor the generating set outlet voltage and frequency by means of the control module LCD display. Check the voltage, if the voltage between phases is 400V and between phase and neutral is 230V. Check that the frequency is 51-52 Hz on generating sets with mechanical governors and 50Hz on generating sets with electronic governors.
- If an engine block water heater is not available, run the generating set at no-load for 8 minutes and when the engine is at normal operating temperature, apply the load. For manual models, apply load to the generating set as follows:
 - Set the alternator outlet circuit breaker on the panel to the ON position.
 - Set the load circuit breakers (or fuses) on the distribution panel to ON position one by one. By performing this step, the generating set cannot be suddenly put under full load. The engine may stall or the alternator winding insulation burning can occur.
 - Set the alternator outlet circuit breaker on the circuit to OFF position before stopping the generating set.
 - Continue to run the unloaded engine for purpose of cooling period for 5 minutes before shutting gen-set down.
 - Never operate the generating set before removing faults if any are present.
 - For an engine installed with a mechanical pump, if the engine speed is observed to fluctuate during the first start-up at customer site, it is the customer's responsibility to regulate the engine speed through adjustment at site. when user want to adjust it ,

please contact AKSA After Sales & Service Dept.

WARNING

Attention

Normally the gen-set cannot run under less than 25% load for a long time. Because inside engine, some parts use pressure for seal, such as between supercharger and supercharger rotor axle. For this kind of seal, when engine has about 1/3 load, which will fully come into play. And under this load, there will be followed failures:

1. Seal between piston and cylinder liner is poor, oil will go up and into combustor, and exhaust will emit blue smoke.
2. As for supercharged diesel gen-sets, because of under low load, no load, low supercharging pressure, it will easily cause the sealing effect (using pressure to seal) of supercharger oil seal (non-contact) to decrease, then oil will go into supercharging chamber and then goes into cylinder together with inlet air.
3. A part of oil which goes into cylinder will take part in combustion; another part of oil cannot combust fully and will form carbon deposit at exhaust pipe. When accumulated oil and carbon deposit are to some extent, they will drip from connector of exhaust manifold.
4. When oil in supercharging chamber of supercharger is accumulated to some extent, it will leak from junction of supercharger.
5. If gen-set runs under load for a long time, it will cause its moving parts to have serious abrading and engine combustion environment will worsen, finally it will cause overhaul ahead of time. So overseas diesel gen-set manufacturers always emphasize to make gen-set not to run under low load or no load as less time as cannot be less than gen-set rated power 25%-30%

17. THE PLACEMENT AND INTALLATION OF AUTOMATIC TRANSFER SWITCH (ATS)

The placement of the transfer switch and its mountings:

- Position the transfer switch near the emergency power panel.
- Locate the transfer switch in a place where it is clean, not over- heated, and good ventilation is present. If the environment temperature is above 40 C (104oF) , breakers will open more easily. There must be enough work space around the transfer switch.
- A breaker may be installed between the generating set and the transfer switch, but it is not required. Current from the generating set must be distributed as equally to the three phases as possible.
- Current from one phase should not exceed the nominal current.
- If the transfer switch panel is apart from the generating set, the ATS must be placed as close as possible to the distributor panel.
- In this case, power cables are drawn from the generating set, the main panel, and emergency power panel. Furthermore, control cables must be drawn from the generating set control panel.

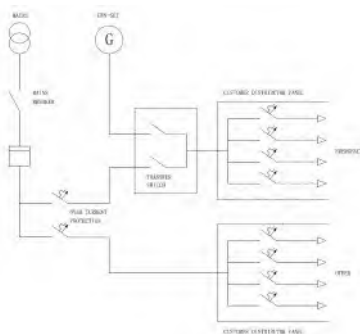

Figure 16.1. Typical emergency power system installation

18. ENGINE TROUBLESHOOTING

The starter motor turns the engine too slowly

- Battery capacity to low
- Bad electrical connection
- Faulty in starter motor
- Wrong grade of lubricating oil

The engine does not start or difficult to start

- Starter motor turns engine too slowly
- Fuel tank empty
- Faulty in fuel control solenoid
- Restriction in a fuel pipe
- Faulty in fuel lift pump
- Dirty fuel filter element
- Air in fuel system
- Faulty in atomizers
- Colt start systems used incorrectly
- Fault in cold start system
- Restriction in fuel tank vent
- Wrong type or grade of fuel used
- Restriction in exhaust pipe

Not enough power

- Restriction in a fuel pipe
- Faulty in fuel lift pump
- Dirty fuel filter element
- Air in fuel system
- Restriction air filter/cleaner or induction system
- Restriction in exhaust pipe
- Fault in atomizers or atomizers of an incorrect type
- Restriction in fuel tank vent
- Wrong type or grade of fuel used
- Restricted movement of engine speed control
- Engine temperature is too high or low

Misfire

- Restriction in a fuel pipe
- Faulty in fuel lift pump
- Dirty fuel filter element

- Air in fuel system
- Fault in atomizers or atomizers of an incorrect type

- Fault in cold start system
- Engine temperature is too high
- Incorrect valve tip clearances

The pressure of the lubrication oil is too low

- Wrong grade of lubrication
- Not enough lubrication oil in sump
- Defective gauge
- Dirty lubrication oil filter element

High fuel consumption

- Restriction air filter/cleaner or induction system
- Fault in atomizers or atomizers of an incorrect type

- Fault in cold start system
- Wrong type or grade of fuel used
- Restricted movement of engine speed control
- Restriction in exhaust pipe
- Engine temperature is too low
- Incorrect valve tip clearances

Black exhaust smoke

- Restriction air filter/cleaner or induction system
- Fault in atomizers or atomizers of an incorrect type

- Fault in cold start system
- Wrong type or grade of fuel used
- Restriction in exhaust pipe
- Engine temperature is too low
- In correct valve tip clearances
- Engine over load

Blue or white exhaust smoke

- Wrong grade of lubrication
- Fault in cold start system
- Engine temperature is too low

The engine knocks

- Faulty in fuel lift pump
- Fault in atomizers or atomizers of an incorrect type

- Wrong type or grade of fuel used
- Fault in cold start system
- Engine temperature is too high
- Incorrect valve tip clearances

The engine runs erratically

- Fault in fuel control
- Restriction in a fuel system
- Fault in fuel lift pump
- Dirty fuel filter element
- Restriction air filter/cleaner or induction system

- Air in fuel system
- Fault in atomizers or atomizers of an incorrect type

- Fault in cold start system
- Restriction in fuel tank vent
- Restricted movement of engine speed control
- Engine temperature is too high
- In correct valve tip clearances

Vibration

- Fault in atomizers or atomizers of an incorrect type

- Restricted movement of engine speed control
- Engine temperature is too high
- Fan damaged
- Fault in engine mounting or flywheel housing
- The engine temperature is too high:
- Restriction air filter/cleaner or induction system
- Fault in atomizers or atomizers of an incorrect type

- Fault in cold start system
- Restriction in exhaust pipe
- Fan damaged
- Too much lubrication oil in pump

- Restriction in air or water passage of radiator
- Insufficient coolant system

Crankcase pressure

- Restriction in breather pipe
- Vacuum pipe leaks or fault in exhauster

Bad compression

- Restriction air filter/cleaner or induction system
- Incorrect valve tip clearances

The engine starts and stops

- Dirty fuel filter element
- Restriction air filter/cleaner or induction system
- Air in fuel system

The engine shuts down after approximately 15 seconds

- Bad connection towards oil pressure switch/
coolant temperature switch

19. MAINTENANCE CHART

aksa POWER GENERATION

PERIODIC MAINTENANCE CHART

QR-SVC-055-01 Rev.03

SYSTEM	MAINTENANCE MODEL	MAINTENANCE CONTENTS	Daily or Every 20 Hours	Weekly	Monthly	3 Months Or 100 Hours	6 Months Or 200 Hours	12 Months Or 500 Hours	24 Months Or 2000 Hours
Lubrication system	Check	Any leakage	*	*	*	*	*	*	*
		Lube-oil level	*	*	*	*	*	*	*
	Replace	Engine oil pressure	Every 12 months.						
		Lube-oil filter					*	*	*
		Lube-oil					*	*	*
Clean	Lube-oil and Lube-oil filter	Oil and oil filter need to be changed for first 50 hours for new or overhauled engine.							
	Breather of crankcase					*	*	*	
Cooling system	Check	Any leakage	*	*	*	*	*	*	*
		Any blocking of radiator			*	*	*	*	*
		Pipes and connectors			*	*	*	*	*
		Coolant level	*	*	*	*	*	*	*
		Anti-rust and anticorrosive			*	*	*	*	*
		Strap and degree of tightness				*	*	*	*
		Fan Drive and water pump				*	*	*	*
	Others	Belt and fan drive of radiator (Optional for remote pulley type radiator)	Every 250 hours						
		Lubricator of fan drive (Optional for remote pulley type radiator)	500 hours						
	Replace	Coolant	Every 12 months						
Cooling system									
Air induction system	Check	Air induction		*	*	*	*	*	*
		Air filter		*	*	*	*	*	*
	Replace	Pipes and connectors				*	*	*	*
Air filter core					*	*	*	*	
Fuel system	Check	Any leakage	*	*	*	*	*	*	*
		Fuel level	*	*	*	*	*	*	*
		Nozzle of fuel pump				*	*	*	*
		Pipes and connectors				*	*	*	*
	Clean	Fuel pump			*	*	*	*	*
		Check fuel tank for dirt			*	*	*	*	*
	Replace	Check the water separator for water					*	*	*
Fuel filter						*	*	*	
Adjust	Nozzle and valves					*	*	*	
	Fuel injection timing	Every 12 months							
Exhaust system	Check	Rocker and valve				*	*	*	*
		Any leakage			*	*	*	*	*
		Exhaust restriction			*	*	*	*	*
Electrical system	Check	Exhaust bolts			*	*	*	*	*
		Charger alternator strap and its degree of tightness			*	*	*	*	*
		Battery	*	*	*	*	*	*	*
	Check	Specific gravity of electrolyte			*	*	*	*	*
		Switch and alarm	*	*	*	*	*	*	*
		Connection of start motor					*	*	*
Others	Check	Starter	Every 12 months						
		Alternator	Every 12 months						
		Tightness of wires	Every 12 months						
		Vibration is normal or not	*	*	*	*	*	*	*
	Clean	Turbocharger bearing clearance					*	*	*
Turbocharger compressor wheel and diffuser						*	*	*	
Operate the gensets under no load for 5 minutes (Optional for standby gensets)	Check	Tightness degree with baseframe					*	*	*
		Generator					*	*	*
		Ease of starting	*						
		Color of exhaust smoke	*						
		Abnormal vibration	*						
	Check	Abnormal noise	*						
		Abnormal smell	*						
Operate the gensets with more than 10 load for 15 minutes (Optional for standby gensets)	Check	Parameter indication	*						
		Ease of starting	*	*	*	*	*	*	
		Color of exhaust smoke	*	*	*	*	*	*	
		Abnormal vibration	*	*	*	*	*	*	
		Abnormal noise	*	*	*	*	*	*	
	Check	Abnormal smell	*	*	*	*	*	*	
		Parameter indication	*	*	*	*	*	*	

*For the engines with manually added lubricant for fuel pump. Lubricant of fuel pump needs to be checked once in every month, and the lubricant shall be replaced once in each three months.

20. PRODUCT WARRANTY REGULATION

Dear valuable customers

Thanks for choosing AKSA diesel generator sets. The Generator Set Warranty Registration Card shall be filled in correctly and returned timely to our company as it will serve as the certificate for obtaining warranty from our company. When an Akxa generator set is to be transferred to a new user, the Product Warranty Regulation shall be transferred to the user together with the generator set.

Scope of Warranty

The warranty regulation is applicable for all diesel generator sets sold by Akxa. Under this regulation, only the failures caused by material and/or manufacturing workmanship defects can be warranted by our company (warrantable failures).

The warranty period is according to Product Warranty Policy(Guide).

Akxa's responsibilities:

Within the basic warranty period of generator set

Akxa will pay for the costs of all parts and reasonable labor hours used to eliminate the warrantable failure(s). Akxa is responsible for paying the reasonable costs for travelling to and from the site of the gen-set to be repaired, including board expenses, travel expenses and accommodation fees.

Akxa shall not be held responsible for any incidental or indirect losses (costs).

When a major failure occurs, such as the engine block, crankshaft or connecting rod or alternator rotor winding was damaged, in order to analyze and judge the true cause of the failure, users shall not disassemble or repair the gen-set without getting approval from Akxa.

Users' responsibilities

Within the basic warranty period of generator set

Users shall be responsible for paying the costs of lubricant oil, anti-freeze and anti-rust, filter element(s), hose(s), belt(s), fuse(s) and indicator lamp(s) and other costs related to maintenance activities for eliminating the warrantable failures. Users shall be responsible for providing the authentic repair and maintenance record of the gen-set.

Warranty limitation

Any failure caused by users' failure to observe the installation guidance contained in Akxa user manual according to Akxa's judgement.

Any failure or damage caused by users' improper use or ignorance, including but not limited to: operate the gen-set without sufficient lubricant oil or coolant; use nonconforming fuel; run the gen-set with over speed; fail to maintain the lubricant system, cooling system or air inlet system according to schedule and/or improperly store, pre-heat, start or stop the gen-sets.

Any failure caused by users' modification of the gen-set without approval from Akxa's technical department.

Any failure caused by users' operation of gen-set with the failure(s) which has (have) occurred or will possibly occur.

Any failure caused by users' failure to operate the gen-set according to the power rating specified on the gen-set's nameplate, including but not limited to: operate the gen-set at the site higher above the specified sea altitude, overload the gen-set and/or operate the gen-set with over current etc.

Any failure caused by the normal wear of parts and/or aging of material(s).

Akxa shall not be responsible for any of the failures caused by the above mentioned reason(s).

21. ELECTRICAL WIRING DIAGRAMS

For an ATS configured with AC contractors, if the mains contactor coil is found to have been damaged while the generator contactor remains intact, it is the customer's responsibility to review if the voltage variation of mains has exceeded the limit of the contactor coil rate voltage, and install a voltage stabilizer at the input of mains contactor coil to prevent such damage when necessary. AKSA shall not be held responsible for such damage.

Please refer to the wiring diagrams which shipped with Gen-set together.

22. TECHNICAL INFORMATION

Model	Cover	Standby Current at 40V ¹ (A)	Cable capacity at 40V ¹ (A)	Cable size V V (mm ²)	Generating Set Dimensions (mm)			Room Dimensions (m)			Radiator Hot Air/Vent Openings/Louvers			Air Inlet Opening Total Area			Room's Door Dimensions (m)			Exhaust		Fuel Consumption (litre/hp/h)	Fly Ash Capacity (t)	Oil Capacity (L)	On specification
					Length	Width	Height	A	B	C	D	E	K	M2	L	M	Diagrams	P (m ²)	Exhaust P (m ²)						
APD1A	10.5	AKR0K15	55.2	25	2.5	1.4	0.70	0.864	3.5	3	2.7	0.7	0.75	0.5	0.8	1.5	2.2	2.5	2	3.12	32	9.1	5	APV 125 or APV 150	
APD2A	17.5	AKR0N19	173	25	2.5	1.4	0.72	0.932	3.5	3	2.7	0.7	0.75	0.5	0.8	1.5	2.2	2.5	2	4.10	32	10.3	6	APV 125 or APV 150	
APD3A	25	AKR0M23	261	42	4	1.666	0.852	1.003	3.5	3	2.7	0.7	0.75	0.5	0.8	1.5	2.2	3	2	6.43	50	15.1	5	APV 125 or APV 150	
APD4A	35	AKR0K27	361	42	4	1.666	0.852	1.003	3.5	3	2.7	0.7	0.75	0.5	0.8	1.5	2.2	3	2	6.43	50	15.1	5	APV 125 or APV 150	
APD5A	44	AKR0K32	461	57	10	1.886	0.892	1.038	3.5	3	2.7	0.7	0.75	0.5	0.8	1.5	2.2	3	2	8.04	60	18.5	10	APV 125 or APV 150	
APD6A	55	AKR0K37	561	70	15	2.015	0.926	1.076	3.5	3	2.7	0.7	0.75	0.5	0.8	1.5	2.2	3	2	10.25	70	21.5	15	APV 125 or APV 150	
APD7A	65	AKR0K41	661	85	20	2.144	0.960	1.136	3.5	3	2.7	0.7	0.75	0.5	0.8	1.5	2.2	3	2	12.46	80	24.5	20	APV 125 or APV 150	
APD8A	75	AKR0K45	761	100	25	2.273	0.994	1.206	3.5	3	2.7	0.7	0.75	0.5	0.8	1.5	2.2	3	2	14.67	90	27.5	25	APV 125 or APV 150	
APD9A	85	AKR0K49	861	120	30	2.402	1.028	1.276	3.5	3	2.7	0.7	0.75	0.5	0.8	1.5	2.2	3	2	16.88	100	30.5	30	APV 125 or APV 150	
APD10A	110	AKR0K53	1061	150	35	2.531	1.062	1.346	3.5	3	2.7	0.7	0.75	0.5	0.8	1.5	2.2	3	2	19.09	110	33.5	35	APV 125 or APV 150	
APD11A	130	AKR0K57	1161	180	40	2.660	1.096	1.416	3.5	3	2.7	0.7	0.75	0.5	0.8	1.5	2.2	3	2	21.30	120	36.5	40	APV 125 or APV 150	
APD12A	150	AKR0K61	1261	220	45	2.789	1.130	1.486	3.5	3	2.7	0.7	0.75	0.5	0.8	1.5	2.2	3	2	23.51	130	39.5	45	APV 125 or APV 150	
APD13A	175	AKR0K65	1361	270	50	2.918	1.164	1.556	3.5	3	2.7	0.7	0.75	0.5	0.8	1.5	2.2	3	2	25.72	140	42.5	50	APV 125 or APV 150	
APD14A	200	AKR0K69	1461	330	55	3.047	1.198	1.626	3.5	3	2.7	0.7	0.75	0.5	0.8	1.5	2.2	3	2	27.93	150	45.5	55	APV 125 or APV 150	
APD15A	225	AKR0K73	1561	400	60	3.176	1.232	1.696	3.5	3	2.7	0.7	0.75	0.5	0.8	1.5	2.2	3	2	30.14	160	48.5	60	APV 125 or APV 150	
APD16A	250	AKR0K77	1661	480	65	3.305	1.266	1.766	3.5	3	2.7	0.7	0.75	0.5	0.8	1.5	2.2	3	2	32.35	170	51.5	65	APV 125 or APV 150	
APD17A	275	AKR0K81	1761	570	70	3.434	1.300	1.836	3.5	3	2.7	0.7	0.75	0.5	0.8	1.5	2.2	3	2	34.56	180	54.5	70	APV 125 or APV 150	
APD18A	300	AKR0K85	1861	660	75	3.563	1.334	1.906	3.5	3	2.7	0.7	0.75	0.5	0.8	1.5	2.2	3	2	36.77	190	57.5	75	APV 125 or APV 150	
APD19A	350	AKR0K89	2061	810	80	3.692	1.368	1.976	3.5	3	2.7	0.7	0.75	0.5	0.8	1.5	2.2	3	2	38.98	200	60.5	80	APV 125 or APV 150	
APD20A	400	AKR0K93	2261	960	85	3.821	1.402	2.046	3.5	3	2.7	0.7	0.75	0.5	0.8	1.5	2.2	3	2	41.19	210	63.5	85	APV 125 or APV 150	
APD21A	450	AKR0K97	2461	1110	90	3.950	1.436	2.116	3.5	3	2.7	0.7	0.75	0.5	0.8	1.5	2.2	3	2	43.40	220	66.5	90	APV 125 or APV 150	
APD22A	500	AKR0K101	2661	1320	95	4.079	1.470	2.186	3.5	3	2.7	0.7	0.75	0.5	0.8	1.5	2.2	3	2	45.61	230	69.5	95	APV 125 or APV 150	
APD23A	550	AKR0K105	2861	1530	100	4.208	1.504	2.256	3.5	3	2.7	0.7	0.75	0.5	0.8	1.5	2.2	3	2	47.82	240	72.5	100	APV 125 or APV 150	
APD24A	600	AKR0K109	3061	1740	105	4.337	1.538	2.326	3.5	3	2.7	0.7	0.75	0.5	0.8	1.5	2.2	3	2	50.03	250	75.5	105	APV 125 or APV 150	
APD25A	650	AKR0K113	3261	1950	110	4.466	1.572	2.396	3.5	3	2.7	0.7	0.75	0.5	0.8	1.5	2.2	3	2	52.24	260	78.5	110	APV 125 or APV 150	
APD26A	700	AKR0K117	3461	2160	115	4.595	1.606	2.466	3.5	3	2.7	0.7	0.75	0.5	0.8	1.5	2.2	3	2	54.45	270	81.5	115	APV 125 or APV 150	
APD27A	750	AKR0K121	3661	2370	120	4.724	1.640	2.536	3.5	3	2.7	0.7	0.75	0.5	0.8	1.5	2.2	3	2	56.66	280	84.5	120	APV 125 or APV 150	
APD28A	800	AKR0K125	3861	2580	125	4.853	1.674	2.606	3.5	3	2.7	0.7	0.75	0.5	0.8	1.5	2.2	3	2	58.87	290	87.5	125	APV 125 or APV 150	
APD29A	850	AKR0K129	4061	2790	130	4.982	1.708	2.676	3.5	3	2.7	0.7	0.75	0.5	0.8	1.5	2.2	3	2	61.08	300	90.5	130	APV 125 or APV 150	
APD30A	900	AKR0K133	4261	3000	135	5.111	1.742	2.746	3.5	3	2.7	0.7	0.75	0.5	0.8	1.5	2.2	3	2	63.29	310	93.5	135	APV 125 or APV 150	
APD31A	950	AKR0K137	4461	3210	140	5.240	1.776	2.816	3.5	3	2.7	0.7	0.75	0.5	0.8	1.5	2.2	3	2	65.50	320	96.5	140	APV 125 or APV 150	
APD32A	1000	AKR0K141	4661	3420	145	5.369	1.810	2.886	3.5	3	2.7	0.7	0.75	0.5	0.8	1.5	2.2	3	2	67.71	330	99.5	145	APV 125 or APV 150	
APD33A	1050	AKR0K145	4861	3630	150	5.498	1.844	2.956	3.5	3	2.7	0.7	0.75	0.5	0.8	1.5	2.2	3	2	69.92	340	102.5	150	APV 125 or APV 150	
APD34A	1100	AKR0K149	5061	3840	155	5.627	1.878	3.026	3.5	3	2.7	0.7	0.75	0.5	0.8	1.5	2.2	3	2	72.13	350	105.5	155	APV 125 or APV 150	
APD35A	1150	AKR0K153	5261	4050	160	5.756	1.912	3.096	3.5	3	2.7	0.7	0.75	0.5	0.8	1.5	2.2	3	2	74.34	360	108.5	160	APV 125 or APV 150	
APD36A	1200	AKR0K157	5461	4260	165	5.885	1.946	3.166	3.5	3	2.7	0.7	0.75	0.5	0.8	1.5	2.2	3	2	76.55	370	111.5	165	APV 125 or APV 150	
APD37A	1250	AKR0K161	5661	4470	170	6.014	1.980	3.236	3.5	3	2.7	0.7	0.75	0.5	0.8	1.5	2.2	3	2	78.76	380	114.5	170	APV 125 or APV 150	
APD38A	1300	AKR0K165	5861	4680	175	6.143	2.014	3.306	3.5	3	2.7	0.7	0.75	0.5	0.8	1.5	2.2	3	2	80.97	390	117.5	175	APV 125 or APV 150	
APD39A	1350	AKR0K169	6061	4890	180	6.272	2.048	3.376	3.5	3	2.7	0.7	0.75	0.5	0.8	1.5	2.2	3	2	83.18	400	120.5	180	APV 125 or APV 150	
APD40A	1400	AKR0K173	6261	5100	185	6.401	2.082	3.446	3.5	3	2.7	0.7	0.75	0.5	0.8	1.5	2.2	3	2	85.39	410	123.5	185	APV 125 or APV 150	
APD41A	1450	AKR0K177	6461	5310	190	6.530	2.116	3.516	3.5	3	2.7	0.7	0.75	0.5	0.8	1.5	2.2	3	2	87.60	420	126.5	190	APV 125 or APV 150	
APD42A	1500	AKR0K181	6661	5520	195	6.659	2.150	3.586	3.5	3	2.7	0.7	0.75	0.5	0.8	1.5	2.2	3	2	89.81	430	129.5	195	APV 125 or APV 150	
APD43A	1550	AKR0K185	6861	5730	200	6.788	2.184	3.656	3.5	3	2.7	0.7	0.75	0.5	0.8	1.5	2.2	3	2	92.02	440	132.5	200	APV 125 or APV 150	
APD44A	1600	AKR0K189	7061	5940	205	6.917	2.218	3.726	3.5	3	2.7	0.7	0.75	0.5	0.8	1.5	2.2	3	2	94.23	450	135.5	205	APV 125 or APV 150	
APD45A	1650	AKR0K193	7261	6150	210	7.046	2.252	3.796	3.5	3	2.7	0.7	0.75	0.5	0.8	1.5	2.2	3	2	96.44	460	138.5	210	APV 125 or APV 150	
APD46A	1700	AKR0K197	7461	6360	215	7.175	2.286	3.866	3.5	3	2.7	0.7	0.75	0.5	0.8	1.5	2.2	3	2	98.65	470	141.5	215	APV 125 or APV 150	
APD47A	1750	AKR0K201	7661	6570	220	7.304	2.320	3.936	3.5	3	2.7	0.7	0.75	0.5	0.8	1.5	2.2	3	2	100.86	480	144.5	220	APV 125 or APV 150	
APD48A	1800	AKR0K205	7861	6780	225	7.433	2.354	4.006	3.5	3	2.7	0.7	0.75	0.5	0.8	1.5	2.2	3	2	103.07	490	147.5	225	APV 125 or APV 150	
APD49A	1850	AKR0K209	8061	6990	230	7.562	2.388	4.076	3.5	3	2.7	0.7	0.75	0.5	0.8	1.5	2.2	3	2	105.28	500	150.5	230	APV 125 or APV 150	
APD50A	1900	AKR0K213	8261	7200	235	7.691	2.422	4.146	3.5	3	2.7	0.7	0.75	0.5	0.8	1.5	2.2	3	2	107.49	510	153.5	235	APV 125 or APV 150	
APD51A	1950	AKR0K217	8461	7410	240	7.820	2.456	4.216	3.5	3	2.7	0.7	0.75	0.5	0.8	1.5	2.2	3	2	109.70	520	156.5	240	APV 125 or APV 150	
APD52A	2000	AKR0K221	8661	7620	245	7.949	2.490	4.286	3.5	3	2.7	0.7	0.75	0.5	0.8	1.5	2.2	3	2	111.91	530	159.5	245	APV 125 or APV 150	
APD53A	2050	AKR0K225	8861	7830	250	8.078	2.524	4.356	3.5	3	2.7	0.7	0.75	0.5	0.8	1.5	2.2</								

Gen-set		Standby Current at 400V (A)		Cable VV Single phase capacity at 40°C (A)		Generating Set Dimensions (m)			Room Dimensions (m)			Radiators / Air Cooled Opposite Louvers			Air Inlet Opening Area (m ²)			Room's Door Dimensions (m)			Exhaust		Fuel Consumption (lit/hr)		Coolant Capacity (L)		Oil Capacity (L)		Oil specification
Model	Engine Model	Standby Current at 400V (A)	Standby Current at 400V (A)	Length	Width	Height	A Length	B Width	C Height	D	E	K	M2	L	M	Diameter (r (inch))	Pin (m)	Consumption (lit/hr)	Fuel Tank Capacity (L)	Oil Capacity (L)	Oil specification								
AP1030P	305	200A-E17FA62	555.7	884	3795	1.15	2.105	5	3.5	3	1.25	1.2	0.7	1.8	1.8	2.5	5	3	71	650	574.4	40	AP10CH-ADES						
AP1340P	410	200A-E17FA62	684	3795	3.21	1.15	2.12	5	3.5	3	1.25	1.2	0.7	1.8	1.8	2.5	5	3	85	850	574.4	40	AP10CH-ADES						
AP1340P	500	200A-E17FA62	884	3795	4.26	1.15	2.12	5	3.5	3	1.25	1.2	0.7	1.8	1.8	2.5	5	3	100	1050	574.4	40	AP10CH-ADES						
AP1340P	600	200A-E17FA62	1084	4720	3.44	1.15	2.105	5	3.5	3	1.25	1.2	0.7	1.8	1.8	2.5	5	3	120	1200	574.4	40	AP10CH-ADES						
AP1340P	800	200A-E17FA62	1382.7	1668	4720	3.44	1.15	2.105	5	3.5	3	1.25	1.2	0.7	1.8	1.8	2.5	5	3	150	1500	574.4	40	AP10CH-ADES					
AP1340P	1000	200A-E17FA62	1780.9	2252	4750	3.401	1.8	2.175	5.5	3.5	1.5	1.2	0.7	2	1.8	2.5	6.3x2	3	132	1750	61	82	AP10CH-ADES						
AP1340P	1200	200A-E17FA62	2252	2925	5155	4.1	2.204	2.44	6	4	1.6	1.6	0.7	3.2	2.8	3	6.3x2	3	152	1500	100.5	68	AP10CH-ADES						
AP1340P	1500	200A-E17FA62	2925	3900	5155	4.1	2.204	2.44	6	4	1.6	1.6	0.7	3.2	2.8	3	6.3x2	3	182	1500	100.5	68	AP10CH-ADES						
AP1340P	1800	400CH-FA	3443.4	5000	400CH-FA	144.4	6.896	2.36	2.459	9	5.5	6	2.2	4	3	3.5	7.6x2	3	215	1600	149	151	AP10CH-ADES						
AP1110P	1100	400H-FA2A	1507.6	1830	6750	6.996	2.679	9	5.5	6	2.2	4	0.3	9	3	3.5	7.6x2	3	175	1600	149	151	AP10CH-ADES						
AP1110P	1250	400H-FA2A	1843.3	2444	6750	6.996	2.679	9	5.5	6	2.2	4	0.3	9	3	3.5	7.6x2	3	244	1600	149	151	AP10CH-ADES						
AP1110P	1500	400H-FA2A	2444	3268	6750	6.996	2.679	9	5.5	6	2.2	4	0.3	9	3	3.5	7.6x2	3	326	1600	149	151	AP10CH-ADES						
AP1110P	1800	400H-FA2A	3268	4448	6750	6.996	2.679	9	5.5	6	2.2	4	0.3	9	3	3.5	7.6x2	3	444	1600	149	151	AP10CH-ADES						
AP1110P	2000	400H-FA2A	4448	5948	6750	6.996	2.679	9	5.5	6	2.2	4	0.3	9	3	3.5	7.6x2	3	594	1600	149	151	AP10CH-ADES						
AP1110P	2250	400H-FA2A	5948	7948	6750	6.996	2.679	9	5.5	6	2.2	4	0.3	9	3	3.5	7.6x2	3	794	1600	149	151	AP10CH-ADES						
AP1110P	2500	400H-FA2A	7948	10448	6750	6.996	2.679	9	5.5	6	2.2	4	0.3	9	3	3.5	7.6x2	3	1044	1600	149	151	AP10CH-ADES						
AP1110P	2750	400H-FA2A	10448	13948	6750	6.996	2.679	9	5.5	6	2.2	4	0.3	9	3	3.5	7.6x2	3	1394	1600	149	151	AP10CH-ADES						
AP1110P	3000	400H-FA2A	13948	18948	6750	6.996	2.679	9	5.5	6	2.2	4	0.3	9	3	3.5	7.6x2	3	1894	1600	149	151	AP10CH-ADES						
AP1110P	3250	400H-FA2A	18948	25948	6750	6.996	2.679	9	5.5	6	2.2	4	0.3	9	3	3.5	7.6x2	3	2594	1600	149	151	AP10CH-ADES						
AP1110P	3500	400H-FA2A	25948	34948	6750	6.996	2.679	9	5.5	6	2.2	4	0.3	9	3	3.5	7.6x2	3	3494	1600	149	151	AP10CH-ADES						
AP1110P	3750	400H-FA2A	34948	46948	6750	6.996	2.679	9	5.5	6	2.2	4	0.3	9	3	3.5	7.6x2	3	4694	1600	149	151	AP10CH-ADES						
AP1110P	4000	400H-FA2A	46948	61948	6750	6.996	2.679	9	5.5	6	2.2	4	0.3	9	3	3.5	7.6x2	3	6194	1600	149	151	AP10CH-ADES						
AP1110P	4250	400H-FA2A	61948	81948	6750	6.996	2.679	9	5.5	6	2.2	4	0.3	9	3	3.5	7.6x2	3	8194	1600	149	151	AP10CH-ADES						
AP1110P	4500	400H-FA2A	81948	106948	6750	6.996	2.679	9	5.5	6	2.2	4	0.3	9	3	3.5	7.6x2	3	10694	1600	149	151	AP10CH-ADES						
AP1110P	4750	400H-FA2A	106948	141948	6750	6.996	2.679	9	5.5	6	2.2	4	0.3	9	3	3.5	7.6x2	3	14194	1600	149	151	AP10CH-ADES						
AP1110P	5000	400H-FA2A	141948	186948	6750	6.996	2.679	9	5.5	6	2.2	4	0.3	9	3	3.5	7.6x2	3	18694	1600	149	151	AP10CH-ADES						
AP1110P	5250	400H-FA2A	186948	251948	6750	6.996	2.679	9	5.5	6	2.2	4	0.3	9	3	3.5	7.6x2	3	25194	1600	149	151	AP10CH-ADES						
AP1110P	5500	400H-FA2A	251948	336948	6750	6.996	2.679	9	5.5	6	2.2	4	0.3	9	3	3.5	7.6x2	3	33694	1600	149	151	AP10CH-ADES						
AP1110P	5750	400H-FA2A	336948	446948	6750	6.996	2.679	9	5.5	6	2.2	4	0.3	9	3	3.5	7.6x2	3	44694	1600	149	151	AP10CH-ADES						
AP1110P	6000	400H-FA2A	446948	596948	6750	6.996	2.679	9	5.5	6	2.2	4	0.3	9	3	3.5	7.6x2	3	59694	1600	149	151	AP10CH-ADES						
AP1110P	6250	400H-FA2A	596948	796948	6750	6.996	2.679	9	5.5	6	2.2	4	0.3	9	3	3.5	7.6x2	3	79694	1600	149	151	AP10CH-ADES						
AP1110P	6500	400H-FA2A	796948	1046948	6750	6.996	2.679	9	5.5	6	2.2	4	0.3	9	3	3.5	7.6x2	3	104694	1600	149	151	AP10CH-ADES						
AP1110P	6750	400H-FA2A	1046948	1396948	6750	6.996	2.679	9	5.5	6	2.2	4	0.3	9	3	3.5	7.6x2	3	139694	1600	149	151	AP10CH-ADES						
AP1110P	7000	400H-FA2A	1396948	1846948	6750	6.996	2.679	9	5.5	6	2.2	4	0.3	9	3	3.5	7.6x2	3	184694	1600	149	151	AP10CH-ADES						
AP1110P	7250	400H-FA2A	1846948	2496948	6750	6.996	2.679	9	5.5	6	2.2	4	0.3	9	3	3.5	7.6x2	3	249694	1600	149	151	AP10CH-ADES						
AP1110P	7500	400H-FA2A	2496948	3346948	6750	6.996	2.679	9	5.5	6	2.2	4	0.3	9	3	3.5	7.6x2	3	334694	1600	149	151	AP10CH-ADES						
AP1110P	7750	400H-FA2A	3346948	4496948	6750	6.996	2.679	9	5.5	6	2.2	4	0.3	9	3	3.5	7.6x2	3	449694	1600	149	151	AP10CH-ADES						
AP1110P	8000	400H-FA2A	4496948	6046948	6750	6.996	2.679	9	5.5	6	2.2	4	0.3	9	3	3.5	7.6x2	3	604694	1600	149	151	AP10CH-ADES						
AP1110P	8250	400H-FA2A	6046948	8046948	6750	6.996	2.679	9	5.5	6	2.2	4	0.3	9	3	3.5	7.6x2	3	804694	1600	149	151	AP10CH-ADES						
AP1110P	8500	400H-FA2A	8046948	10546948	6750	6.996	2.679	9	5.5	6	2.2	4	0.3	9	3	3.5	7.6x2	3	1054694	1600	149	151	AP10CH-ADES						
AP1110P	8750	400H-FA2A	10546948	14046948	6750	6.996	2.679	9	5.5	6	2.2	4	0.3	9	3	3.5	7.6x2	3	1404694	1600	149	151	AP10CH-ADES						
AP1110P	9000	400H-FA2A	14046948	18546948	6750	6.996	2.679	9	5.5	6	2.2	4	0.3	9	3	3.5	7.6x2	3	1854694	1600	149	151	AP10CH-ADES						
AP1110P	9250	400H-FA2A	18546948	24546948	6750	6.996	2.679	9	5.5	6	2.2	4	0.3	9	3	3.5	7.6x2	3	2454694	1600	149	151	AP10CH-ADES						
AP1110P	9500	400H-FA2A	24546948	32546948	6750	6.996	2.679	9	5.5	6	2.2	4	0.3	9	3	3.5	7.6x2	3	3254694	1600	149	151	AP10CH-ADES						
AP1110P	9750	400H-FA2A	32546948	43546948	6750	6.996	2.679	9	5.5	6	2.2	4	0.3	9	3	3.5	7.6x2	3	4354694	1600	149	151	AP10CH-ADES						
AP1110P	10000	400H-FA2A	43546948	58546948	6750	6.996	2.679	9	5.5	6	2.2	4	0.3	9	3	3.5	7.6x2	3	5854694	1600	149	151	AP10CH-ADES						
AP1110P	10250	400H-FA2A	58546948	78546948	6750	6.996	2.679	9	5.5	6	2.2	4	0.3	9	3	3.5	7.6x2	3	7854694	1600	149	151	AP10CH-ADES						
AP1110P	10500	400H-FA2A	78546948	103546948	6750	6.996	2.679	9	5.5	6	2.2	4	0.3	9	3	3.5	7.6x2	3	10354694	1600	149	151	AP10CH-ADES						
AP1110P	10750	400H-FA2A	103546948	138546948	6750	6.996	2.679	9	5.5	6	2.2	4	0.3	9	3	3.5	7.6x2	3	13854694	1600	149	151	AP10CH-ADES						
AP1110P	11000	400H-FA2A	138546948	183546948	6750	6.996	2.679	9	5.5	6	2.2	4	0.3	9	3	3.5	7.6x2	3	18354694	1600	149	151	AP10CH-ADES						
AP1110P	11250	400H-FA2A	183546948	243546948	6750	6.996	2.679	9	5.5	6	2.2	4	0.3	9	3	3.5	7.6x2	3	24354694	1600	149	151	AP10CH-ADES						
AP1110P	11500	400H-FA2A	243546948	323546948	6750	6.996	2.679	9	5.5	6	2.2	4	0.3	9	3	3.5	7.6x2	3	32354694	1600	149	151	AP10CH-ADES						
AP1110P	11750	400H-FA2A	323546948	433546948	6750	6.996	2.679	9	5.5	6	2.2	4	0.3	9	3	3.5	7.6x2	3	43354694	1600	149	151	AP10CH-ADES						
AP1110P	12000	400H-FA2A	433546948	583546948	6750	6.996	2.679	9	5.5	6	2.2	4	0.3	9	3	3.5	7.6x2	3	58354694	1600	149	151	AP10CH-ADES						
AP1110P	12250	400H-FA2A	583546948	783546948	6750	6.996	2.679	9	5.5	6	2.2	4	0.3	9	3	3.5	7.6x2	3	78354694	1600	149	151	AP10CH-ADES						
AP1110P	12500	400H-FA2A	783546948	1033546948	6750	6.9																							

AKSA FACTORIES



TURKEY
Aksa Turkey(Head Office)
Ruzgarlibahce Mah, Selvi Cikmazi
No:10 34805 Kavacik-Beykoz
Istanbul/Turkey
T: +90 216 681 00 00
F: +90 216 681 57 91
E-mail: aksa@aksa.com.tr
Website: www.aksa.com.tr



CHINA
Aksa China
Aksa Power Generation(China)
No.19 Tongjiang North Road,
Changzhou New District,
Changzhou/China
T: +86(0)519 85150 205
F: +86(0)519 85150 130
E-mail: aksa@aksapowergen.com



U.S.A
Aksa USA
10399 Silver Springs Rd, Conroe,
TX 77303, Houston
T: 318 855 8377
E-mail: sales@aksausa.com
Website: www.aksausa.com



SPAIN
Aksa Spain
Pol. Centrovía, c / Panamá, 12 La
Muela 50198 Zaragoza
T: +34 976 14 16 55
E-mail: info@dagartech.com



SOUTH AFRICA
Aksa South Africa
X4 Syferfontein, Beethoven Road
Hartbeespoort, 0216
T: +27 64 750 2696
E-mail: sales@deltagen.co.za

AKSA WORLDWIDE



ALGERIA
Aksa Algeria
Eurl Aksa Generateurs Algerie
Zone Industrielle Oued Smar Lot
No:55 Harrach/Alger/Algerie
T: +213 23 92 06 56-57-58
E-mail: contact@aksa-dz.com



VIETNAM
Aksa Vietnam
21 Huynh Tinh Cua, p. Vo Thi Sau,
Q. 3 Ho Chi Minh City, Vietnam
T: +848 391 47 014
F: +848 391 47 015
E-mail: vietnam@aksapowergen.com



KAZAKHSTAN
Aksa Kazakhstan
89a Suynbay ave. Almaty
City/KAZAKHSTAN
T: +7 727 338 48 47
E-mail: info@aksakz.kz
Website: www.aksakz.kz



SINGAPORE
Aksa Singapore
94 Tuas Avenue 11 639103
Singapore
T: +65 6863 2832
E-mail: aksafe@aksafareast.com.sg



U.A.E
Aksa Middle East
Po Box: 18167, No.S20128, Jebel Ali
Free Zone South, Dubai , UAE
T: +971 4 8809140
E-Mail: sales@aksauae.com



UZBEKISTAN
Aksa Power
Republic of Uzbekistan, 100015,
Tashkent city Oybek street 22 No.
C-5 on the 3 floor
T: +998(78)150 27 47
E-mail: info@aksa.uz



GHANA
Aksa Ghana
PT MC.4 Tema Motorway
Industrial Area Extension off
Spintex RD, Accra / GHANA
T: +233 (0) 302 979 862
e-mail: info@aksaghana.com



KENYA
Aksa Kenya
Sunflag Industrial Park
No:3 Mombasa Rd. P.O.
Box 196-00519 Nairobi,
Kenya
T: +254 792 423 559
e-mail: info@aksakenya.com



INDONESIA
Aksa Indonesia
PT Aksa Power Indonesia
Menara Palma Lantai 3 unit 3-03 Jalan HR
Rasuna Said Blok X2 Kav.6 Kelurahan
Kuningan Timur Kecamatan Setabudi
Jakarta Selatan, Jakarta, INDONESIA
Po Box:12950
T: 021 5795 7590
E-mail: info@aksaindonesia.co.id
Website: www.aksaindonesia.co.id



SUDAN
Aksa Sudan
Apartment 86, Macca Street, AL
Riyadh, Khartoum-SUDAN
E-mail: murat@aksasudan.com



UNITED KINGDOM
Aksa UK
Unit 6, Pine Court Walker Road,
Bardon Hill Coalville Leicestershire
LE67 ISZ U.Kingdom
T: +44 (0) 1530 837 472
E-mail: info@aksauk.com



NETHERLANDS
Aksa Europe
Merwedestraat 48P 3313CS, Dordrecht/
the Netherlands
T: +31 (0) 78-204 9129
E-mail: sales@aksaeurope.com